

DataSheet

MT-T424

This document contains the specifications for MT-T424. Specifications are typical at 25°C unless otherwise noted.



Caution Using the MT-T424 in a manner not described in this document may impair the protection the MT-T424 provides.

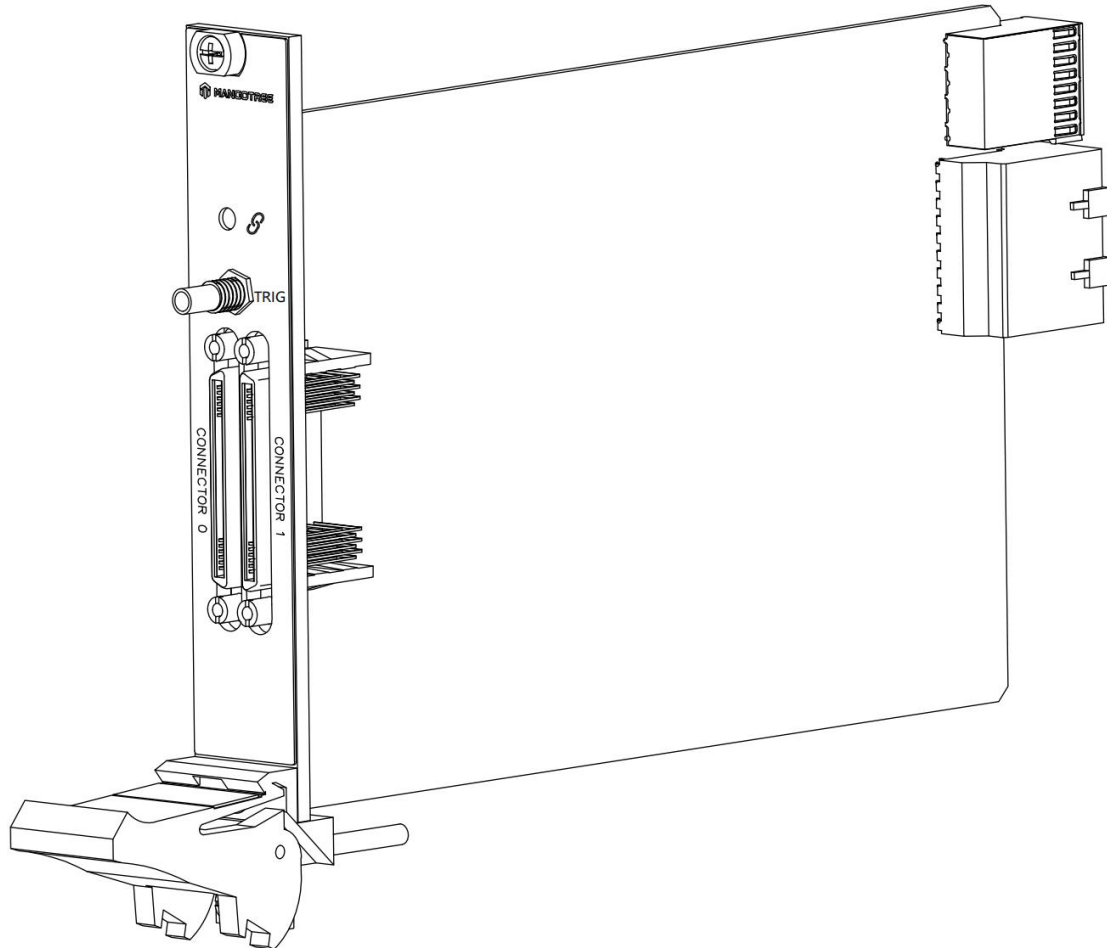

Analog Input

Number of channels	32 differential
ADC resolution	16 bits
Type of ADC	Successive approximation register (SAR)
Input range	±25mA
Overvoltage protection	±30 V
Sample mode	simultaneous
Sample rate	800 kS/s maximum

Table 1. Accuracy

	Measurement Conditions	Percent of Reading (Gain Error)	Percent of Range (Offset Error)
Calibrated	Maximum (-40 °C to 70 °C)	±0.20%	±0.09%
	Typical (23 °C ±5 °C)	±0.08%	±0.03%

CMRR	120 dB minimum
-3 dB bandwidth	>85 kHz
Input impedance(AI+ to AI-)	12 mΩ
Input noise	
RMS	1LSBrms
Peak-toPeak	7LSB
Crosstalk	-90 dB
Settling time (to 2 LSBs)	5.5us
External Digital Triggers	
Number of triggers	10
Source	TRIG, PXI_TRIG<0..7>, PXI_STAR

Maximum Power Requirements

Power requirements are dependent on the digital output loads and configuration of the LabVIEW FPGA VI used in your application.

+3.3V	1.23 A
-------	--------

+12 V

0.57 A

Physical Characteristics

Weight

200g

Dimensions

See end of this document

Safety Voltages

This product is designed to meet the requirements of the following electrical equipment safety standards for measurement, control, and laboratory use:

- IEC 61010-1, EN 61010-1
- UL 61010-1, CSA C22.2 No. 61010-1

CE Compliance

This product meets the essential requirements of applicable European Directives, as follows:

- 2014/35/EU; Low-Voltage Directive (safety)
- 2014/30/EU; Electromagnetic Compatibility Directive (EMC)
- 2014/34/EU; Potentially Explosive Atmospheres (ATEX)

Shock and Vibration

To meet these specifications, you must panel mount the system.

Operating vibration

Random (IEC 60068-2-64)

5 g_{rms}, 10 Hz to 500 Hz

Sinusoidal (IEC 60068-2-6)

5 g, 10 Hz to 500 Hz

Operating shock (IEC 60068-2-27)

30 g, 11 ms half sine; 50 g, 3 ms half sine;
18 shocks at 6 orientations

Environmental

Refer to the manual for the chassis you are using for more information about meeting these specifications.

Operating temperature	-40 °C to 70 °C (IEC 60068-2-1, IEC 60068-2-2)
Storage temperature	-40 °C to 85 °C (IEC 60068-2-1, IEC 60068-2-2)
Ingress protection	IP40
Operating humidity (IEC 60068-2-78)	10% RH to 90% RH, noncondensing Storage
humidity (IEC 60068-2-78)	5% RH to 95% RH, noncondensing Pollution
Degree	2
Maximum altitude	4,000 m

Indoor use only.

DAQMode Support

通用模式 (DAQMode=0) 包括: AI、AO、Counter、PWM、Encoder、Digital Input、Digital Output、Digital Waveform Input、Digital Waveform Output、Temperature。

通用模式适用所有的MT-DAQ设备, 该模式下用户可以开发使用设备数据手册中说明的全部功能, 不同设备支持的功能不同。本设备通用模式支持的功能如下表所示, 对应功能为绿色则支持, 红色则不支持。

本设备通用模式 (DAQMode=0) 支持的功能:

● AI	● AO
● Counter	● PWM
● Encoder	● Temperature
● Digital Input	● Digital Output
● Digital Waveform Input	● Digital Waveform Output

特殊模式包括: AI/AO同步 (AIO Sync)、编码器触发AI (Encoder Trigger AI)、AI触发编码器 (AI Trigger Encoder)、DI触发AI/AO同步 (DI Trigger AIO)、DI触发AI (DI Trigger AI)、DI触发AO (DI Trigger AO)。

如果需要使用特殊模式下的模式, 用户需要确认购买设备是否支持该模式, 本设备支持的特殊模式如下表所示, 对应模式为绿色则支持, 红色则不支持; Customer是定制DAQ模式, 正常用户无法使用。如果模式配置错误, 会导致设备无法正常运行。

本设备支持的特殊模式:

● AO-Sync-AI (DAQMode=1)	● AI-Trigger-Encoder (DAQMode=2)
● Encoder-Trigger-AI (DAQMode=3)	● DI-Trigger-AI-Sync-AO (DAQMode=4)
● DI-Trigger-AI (DAQMode=5)	● DI-Trigger-AO (DAQMode=6)

Config文本

MT-DAQ设备的开发和使用依赖于Config配置文本，只有正确配置该文本，才能保证设备的正常运行。不同型号的设备或板卡对应的配置参数是不同的。Python、LabVIEW和C#三种编程语言的Config配置文本完全相同。

通用Config配置文本通过MT-Master软件主页导出获得，用户可以根据实际设备或板卡的参数对配置文本进行修改配置，或者按照文本默认参数配置运行。

Config配置文本中的各项参数含义及其具体配置可以参考MT-DAQ上手指南，指南链接附于下文Support板块。

使用MT产品过程中如有任何疑问，可以通过访问官网：<http://www.mangotree.cn>联系专业客服咨询。



MangoTree官网

Support

MT-Master上手指南:

<https://server.mangotree.cn:9900/WebFile/Downloads/上手指南/MT-Master/>



Master上手指南

MT-Master视频教程:

<https://server.mangotree.cn:9900/WebFile/Downloads/视频教程/MT-Master/>



Master视频教程

MT-DAQ上手指南:

<https://server.mangotree.cn:9900/WebFile/Downloads/上手指南/MT-DAQ/>



DAQ上手指南

MT-DAQ视频教程:

<https://server.mangotree.cn:9900/WebFile/Downloads/视频教程/MT-DAQ/>



DAQ视频教程

MT-T424 Pinout

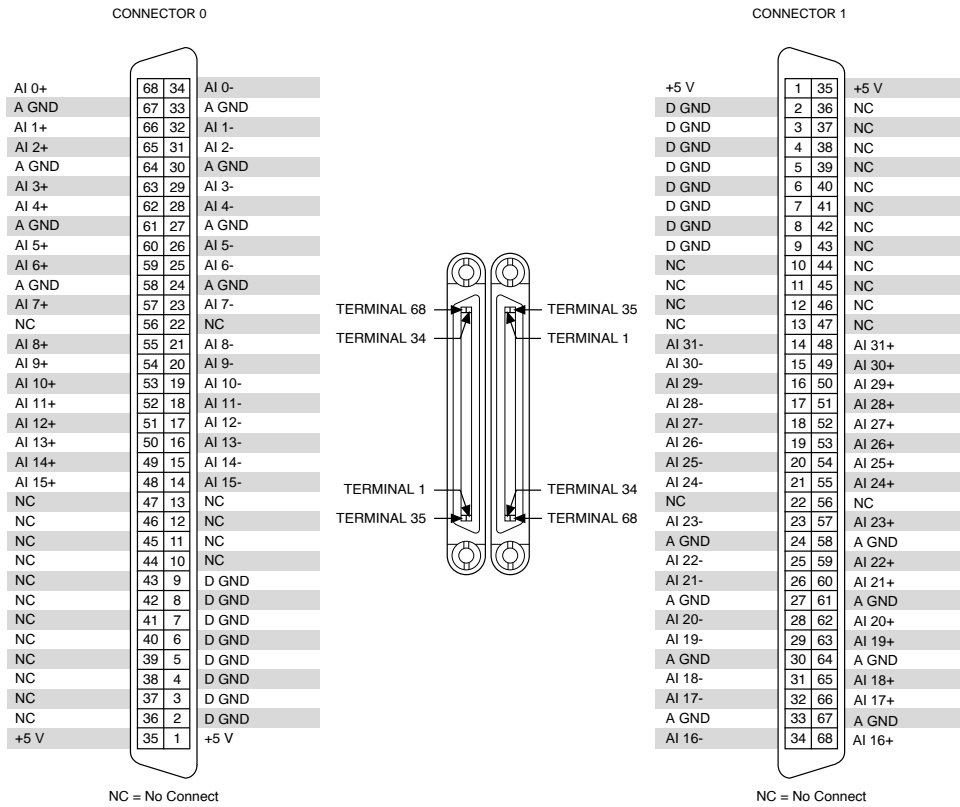

Dimensions

