

DataSheet

MT-T534

This document contains the specifications for MT-T534. Specifications are typical at 25°C unless otherwise noted.



Caution Using the MT-T534 in a manner not described in this document may impair the protection the MT-T534 provides.

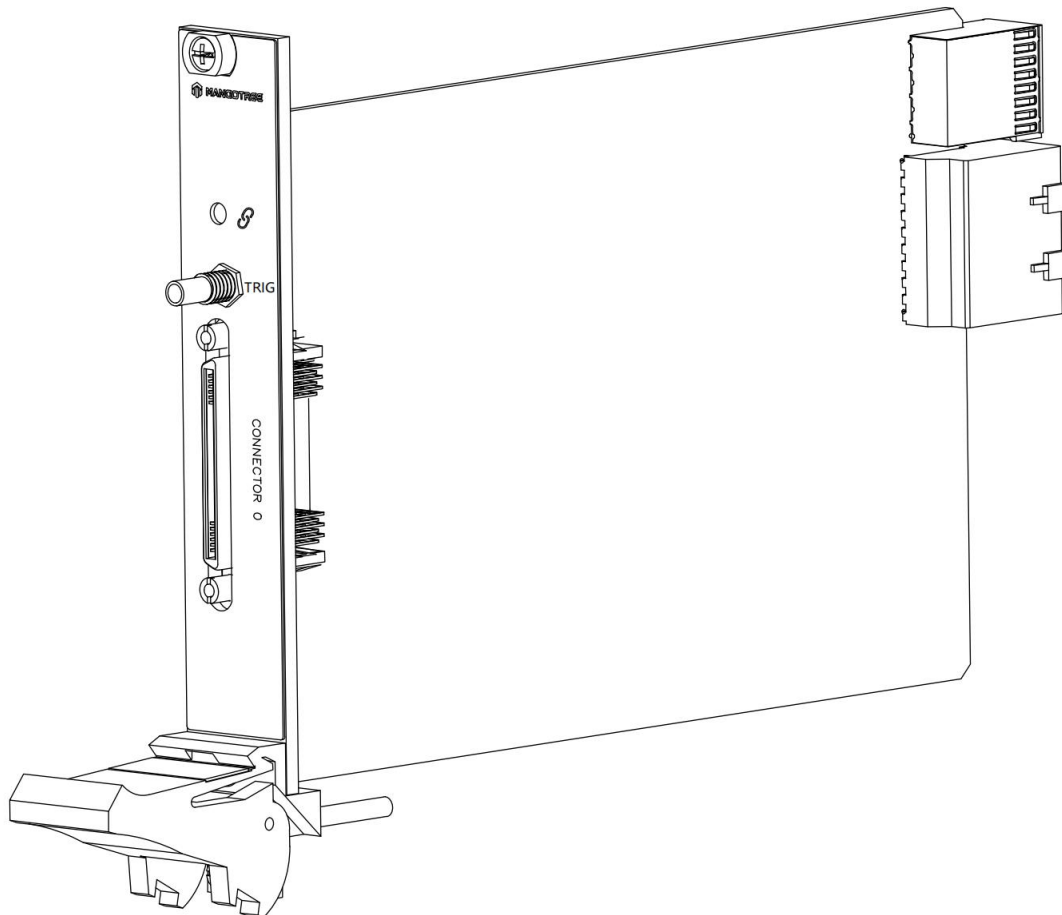

Analog Output

Number of channels	16
DAC resolution	16 bits
Type of DAC	String
Output voltage range	$\pm 10\text{V}$
Current drive	$\pm 10\text{ mA}$ per channel maximum
Output impedance	$375\ \Omega$
Sample rate	1 MS/s maximum per channel

Table 1. Accuracy

Measurement Conditions		Percent of Reading (Gain Error)	Percent of Range (Offset Error)
Calibrated	Maximum (-40 °C to 70 °C)	0.214%	0.075%
	Typical (25 °C, $\pm 5\text{ °C}$)	0.010%	0.007%

Gain drift	$\pm 0.1\text{ ppm}/^\circ\text{C}$
Zero-code drift	$\pm 0.05\text{ ppm}/^\circ\text{C}$
Protection	
Overvoltage	$\pm 30\text{V}$
Short-circuit	Indefinitely
Noise	
Output noise	$10\text{nV} / \sqrt{\text{Hz}}$
Slew rate	$25\text{V}/\mu\text{s}$
Crosstalk	74dB
Capacitive drive	1nF
DNL	$\pm 1\text{ LSB}$ maximum
INL (endpoint)	$\pm 1\text{ LSB}$ maximum

Counter

Voltage Level	5V
---------------	----

Number of Channels	2
Counter measurements	Edge counting,pulse,pulse width,frequency
Maximum input frequency	2MHz

PWM

Voltage Level	5V
Number of Channels	2
Maximum output frequency	500kHz

Encoder

Voltage Level	5V
Number of Channels	1 (each with A,B,Z)
Position measurements	Quadrature encoding

Figure 1. Quadrature encoding

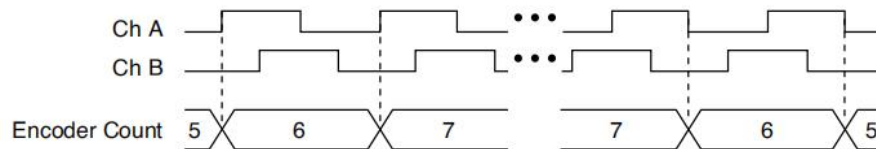

Digital Trigger

Voltage Level	5V
Number of Channels	1

Digital Waveform Input/Output

Voltage Level	5V
Number of Channel	1 Digital Waveform In, 1 Digital Waveform Out
Maximum update rate	5MHz

Digital Input/Output

Voltage Level	5V
Number of Channel	3 Digital Input, 3 Digital Output
Maximum update rate	500Hz

External Digital Triggers

Number of triggers	11
Source	Digital Trigger, TRIG, PXI_TRIG<0..7>, PXI_STAR

Maximum Power Requirements

Power requirements are dependent on the digital output loads and configuration of the LabVIEW FPGA VI used in your application.

+3.3V	1.23 A
+12 V	0.57 A

Physical Characteristics

Weight	200g
Dimensions	See end of this document

Safety Voltages

This product is designed to meet the requirements of the following electrical equipment safety standards for measurement, control, and laboratory use:

- IEC 61010-1, EN 61010-1
- UL 61010-1, CSA C22.2 No. 61010-1

CE Compliance

This product meets the essential requirements of applicable European Directives, as follows:

- 2014/35/EU; Low-Voltage Directive (safety)
- 2014/30/EU; Electromagnetic Compatibility Directive (EMC)
- 2014/34/EU; Potentially Explosive Atmospheres (ATEX)

Shock and Vibration

To meet these specifications, you must panel mount the system.

Operating vibration

Random (IEC 60068-2-64)	5 g _{rms} , 10 Hz to 500 Hz
Sinusoidal (IEC 60068-2-6)	5 g, 10 Hz to 500 Hz
Operating shock (IEC 60068-2-27)	30 g, 11 ms half sine; 50 g, 3 ms half sine; 18 shocks at 6 orientations

Environmental

Refer to the manual for the chassis you are using for more information about meeting these specifications.

Operating temperature	-40 °C to 70 °C (IEC 60068-2-1, IEC 60068-2-2)
Storage temperature	-40 °C to 85 °C (IEC 60068-2-1, IEC 60068-2-2)
Ingress protection	IP40
Operating humidity (IEC 60068-2-78)	10% RH to 90% RH, noncondensing Storage
humidity (IEC 60068-2-78)	5% RH to 95% RH, noncondensing Pollution
Degree	2
Maximum altitude	4,000 m

Indoor use only.

DAQMode Support

通用模式 (DAQMode=0) 包括: AI、AO、Counter、PWM、Encoder、Digital Input、Digital Output、Digital Waveform Input、Digital Waveform Output、Temperature。

通用模式适用所有的MT-DAQ设备, 该模式下用户可以开发使用设备数据手册中说明的全部功能, 不同设备支持的功能不同。本设备通用模式支持的功能如下表所示, 对应功能为绿色则支持, 红色则不支持。

本设备通用模式 (DAQMode=0) 支持的功能:

● AI	● AO
● Counter	● PWM
● Encoder	● Temperature
● Digital Input	● Digital Output
● Digital Waveform Input	● Digital Waveform Output

特殊模式包括: AI/AO同步 (AIO Sync)、编码器触发AI (Encoder Trigger AI)、AI触发编码器 (AI Trigger Encoder)、DI触发AI/AO同步 (DI Trigger AIO)、DI触发AI (DI Trigger AI)、DI触发AO (DI Trigger AO)。

如果需要使用特殊模式下的模式, 用户需要确认购买设备是否支持该模式, 本设备支持的特殊模式如下表所示, 对应模式为绿色则支持, 红色则不支持; Customer是定制DAQ模式, 正常用户无法使用。如果模式配置错误, 会导致设备无法正常运行。

本设备支持的特殊模式:

● AO-Sync-AI (DAQMode=1)	● AI-Trigger-Encoder (DAQMode=2)
● Encoder-Trigger-AI (DAQMode=3)	● DI-Trigger-AI-Sync-AO (DAQMode=4)
● DI-Trigger-AI (DAQMode=5)	● DI-Trigger-AO (DAQMode=6)

Config文本

MT-DAQ设备的开发和使用依赖于Config配置文本，只有正确配置该文本，才能保证设备的正常运行。不同型号的设备或板卡对应的配置参数是不同的。Python、LabVIEW和C#三种编程语言的Config配置文本完全相同。

通用Config配置文本通过MT-Master软件主页导出获得，用户可以根据实际设备或板卡的参数对配置文本进行修改配置，或者按照文本默认参数配置运行。

Config配置文本中的各项参数含义及其具体配置可以参考MT-DAQ上手指南，指南链接附于下文Support板块。

使用MT产品过程中如有任何疑问，可以通过访问官网：<http://www.mangotree.cn>联系专业客服咨询。



MangoTree官网

Support

MT-Master上手指南:

<https://server.mangotree.cn:9900/WebFile/Downloads/上手指南/MT-Master/>



Master上手指南

MT-Master视频教程:

<https://server.mangotree.cn:9900/WebFile/Downloads/视频教程/MT-Master/>



Master视频教程

MT-DAQ上手指南:

<https://server.mangotree.cn:9900/WebFile/Downloads/上手指南/MT-DAQ/>



DAQ上手指南

MT-DAQ视频教程:

<https://server.mangotree.cn:9900/WebFile/Downloads/视频教程/MT-DAQ/>



DAQ视频教程

MT-T534 Pinout

CONNECTOR 0

AO 0	68	34	NC
A GND	67	33	A GND
AO 1	66	32	NC
AO 2	65	31	NC
A GND	64	30	A GND
AO 3	63	29	NC
AO 4	62	28	NC
A GND	61	27	A GND
AO 5	60	26	NC
AO 6	59	25	NC
A GND	58	24	A GND
AO 7	57	23	NC
A GND	56	22	A GND
AO 8	55	21	NC
AO 9	54	20	NC
AO 10	53	19	NC
AO 11	52	18	NC
AO 12	51	17	NC
AO 13	50	16	NC
AO 14	49	15	NC
AO 15	48	14	NC
Digital Trigger	47	13	Digital Waveform Out 0
Digital Waveform In 0	46	12	Digital Output 2
Digital Output 1	45	11	Digital Output 0
Digital Input 2	44	10	Digital Input 1
Digital Input 0	43	9	D GND
Counter 1	42	8	D GND
Counter 0	41	7	D GND
PWM 1	40	6	D GND
PWM 0	39	5	D GND
Encoder0.C	38	4	D GND
Encoder0.B	37	3	D GND
Encoder0.A	36	2	D GND
+5 V	35	1	+5 V

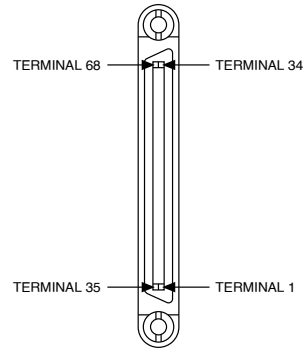

Dimensions

