

DataSheet

MT-T564

This document contains the specifications for MT-T564. Specifications are typical at 25°C unless otherwise noted.



Caution Using the MT-T564 in a manner not described in this document may impair the protection the MT-T564 provides.

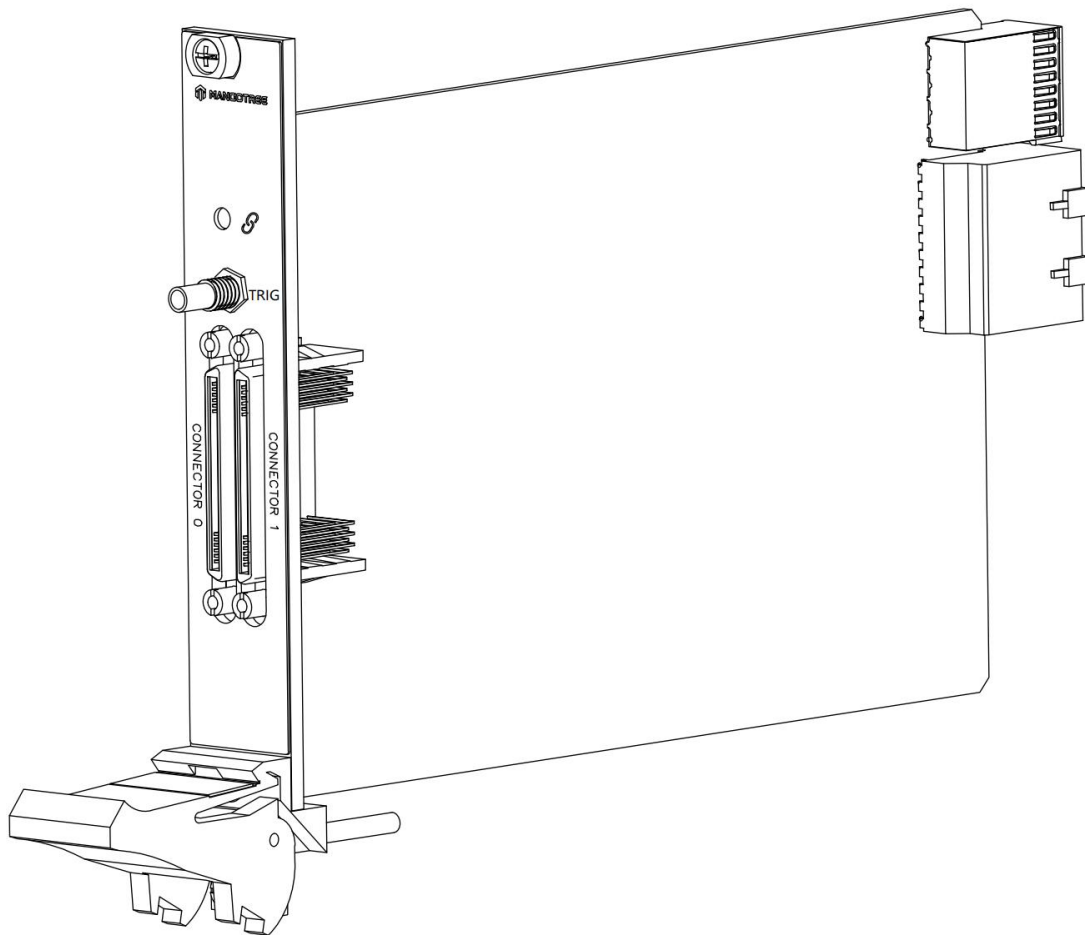

Analog Input

| | |
|----------------------------------|---|
| Number of channels | 8 differential |
| ADC resolution | 16 bits |
| Type of ADC | Successive approximation register (SAR) |
| Input range | $\pm 10V$ |
| Input Voltage Ranges | |
| Measurement Voltage (AI+ to AI-) | |
| Minimum(V) | $\pm 10.2V$ |
| Typical(V) | $\pm 10.4V$ |
| Maximum | $\pm 10.6V$ |
| Overvoltage protection | $\pm 30 V$ |
| Conversion time | 1 μs minimum |
| Sample rate | 1 MS/s maximum per channel |

Table 1. Accuracy

| Measurement Conditions | | Percent of Reading (Gain Error) | Percent of Range (Offset Error) |
|------------------------|----------------------------|------------------------------------|------------------------------------|
| Calibrated | Maximum (-40 °C to 70 °C) | 0.142% | $\pm 0.070\%$ |
| | Typical (23 °C ± 5 °C) | 0.010% | $\pm 0.007\%$ |

| | |
|--------------------------------|----------------|
| CMRR | 120 dB minimum |
| -3 dB bandwidth | >15 kHz |
| Input impedance | 1M Ω |
| Crosstalk | -90 dB |
| Total Harmonic Distortion(THD) | -107dB |
| No missing codes | 16 bits |
| DNL | $\pm 0.4LSB$ |
| INL | $\pm 0.5LSB$ |
| SNR | 90 dB |
| SFDR | 109 dB |

Analog Output

| | |
|----------------------|--|
| Number of channels | 24 |
| DAC resolution | 16 bits |
| Type of DAC | String |
| Output voltage range | $\pm 10\text{V}$ |
| Current drive | $\pm 10\text{ mA}$ per channel maximum |
| Output impedance | $375\ \Omega$ |
| Sample rate | 1 MS/s maximum per channel |

Table 2. Accuracy

| Measurement Conditions | | Percent of Reading (Gain Error) | Percent of Range (Offset Error) |
|------------------------|-------------------------------------|------------------------------------|------------------------------------|
| Calibrated | Maximum (-40 °C to 70 °C) | 0.214% | 0.075% |
| | Typical (25 °C, $\pm 5\text{ °C}$) | 0.010% | 0.007% |

| | |
|------------------|--------------------------------------|
| Gain drift | $\pm 0.1\text{ ppm}/^\circ\text{C}$ |
| Zero-code drift | $\pm 0.05\text{ ppm}/^\circ\text{C}$ |
| Protection | |
| Overvoltage | $\pm 30\text{V}$ |
| Short-circuit | Indefinitely |
| Noise | |
| Output noise | $10\text{nV} / \sqrt{\text{Hz}}$ |
| Slew rate | $25\text{V}/\mu\text{s}$ |
| Crosstalk | 74dB |
| Capacitive drive | 1nF |
| DNL | $\pm 1\text{ LSB}$ maximum |
| INL (endpoint) | $\pm 1\text{ LSB}$ maximum |

Counter

| | |
|-------------------------|---|
| Voltage Level | 5V |
| Number of Channels | 4 |
| Counter measurements | Edge counting,pulse,pulse width,frequency |
| Maximum input frequency | 2MHz |

PWM

| | |
|--------------------------|--------|
| Voltage Level | 5V |
| Number of Channels | 4 |
| Maximum output frequency | 500kHz |

Encoder

| | |
|-----------------------|---------------------|
| Voltage Level | 5V |
| Number of Channels | 2 (each with A,B,Z) |
| Position measurements | Quadrature encoding |

Figure 1. Quadrature encoding

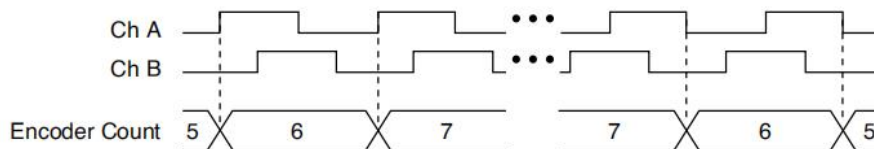

Digital Trigger

| | |
|--------------------|----|
| Voltage Level | 5V |
| Number of Channels | 2 |

Digital Waveform Input/Output

| | |
|-------------------|---|
| Voltage Level | 5V |
| Number of Channel | 2 Digital Waveform In, 2 Digital Waveform Out |

| | |
|---------------------|------|
| Maximum update rate | 5MHz |
|---------------------|------|

Digital Input/Output

| | |
|---------------------|----------------------------------|
| Voltage Level | 5V |
| Number of Channel | 6 Digital Input,6 Digital Output |
| Maximum update rate | 500Hz |

External Digital Triggers

| | |
|--------------------|---|
| Number of triggers | 12 |
| Source | Digital Triggers,TRIG,PXI_TRIG<0..7>, PXI_STAR |

Maximum Power Requirements

Power requirements are dependent on the digital output loads and configuration of the LabVIEW FPGA VI used in your application.

| | |
|-------|--------|
| +3.3V | 1.23 A |
| +12 V | 0.57 A |

Physical Characteristics

| | |
|------------|--------------------------|
| Weight | 200g |
| Dimensions | See end of this document |

Safety Voltages

This product is designed to meet the requirements of the following electrical equipment safety standards for measurement, control, and laboratory use:

- IEC 61010-1, EN 61010-1
- UL 61010-1, CSA C22.2 No. 61010-1

CE Compliance

This product meets the essential requirements of applicable European Directives, as follows:

- 2014/35/EU; Low-Voltage Directive (safety)
- 2014/30/EU; Electromagnetic Compatibility Directive (EMC)
- 2014/34/EU; Potentially Explosive Atmospheres (ATEX)

Shock and Vibration

To meet these specifications, you must panel mount the system.

Operating vibration

| | |
|----------------------------------|---|
| Random (IEC 60068-2-64) | 5 g _{rms} , 10 Hz to 500 Hz |
| Sinusoidal (IEC 60068-2-6) | 5 g, 10 Hz to 500 Hz |
| Operating shock (IEC 60068-2-27) | 30 g, 11 ms half sine; 50 g, 3 ms half sine; 18 shocks at 6 orientations |

Environmental

Refer to the manual for the chassis you are using for more information about meeting these specifications.

| | |
|-------------------------------------|---|
| Operating temperature | -40 °C to 70 °C (IEC 60068-2-1, IEC 60068-2-2) |
| Storage temperature | -40 °C to 85 °C (IEC 60068-2-1, IEC 60068-2-2) |
| Ingress protection | IP40 |
| Operating humidity (IEC 60068-2-78) | 10% RH to 90% RH, noncondensing Storage |
| humidity (IEC 60068-2-78) | 5% RH to 95% RH, noncondensing Pollution |
| Degree | 2 |
| Maximum altitude | 4,000 m |

Indoor use only.

DAQMode Support

通用模式 (DAQMode=0) 包括: AI、AO、Counter、PWM、Encoder、Digital Input、Digital Output、Digital Waveform Input、Digital Waveform Output、Temperature。

通用模式适用所有的MT-DAQ设备, 该模式下用户可以开发使用设备数据手册中说明的全部功能, 不同设备支持的功能不同。本设备通用模式支持的功能如下表所示, 对应功能为绿色则支持, 红色则不支持。

本设备通用模式 (DAQMode=0) 支持的功能:

| | |
|--------------------------|---------------------------|
| ● AI | ● AO |
| ● Counter | ● PWM |
| ● Encoder | ● Temperature |
| ● Digital Input | ● Digital Output |
| ● Digital Waveform Input | ● Digital Waveform Output |

特殊模式包括: AI/AO同步 (AIO Sync)、编码器触发AI (Encoder Trigger AI)、AI触发编码器 (AI Trigger Encoder)、DI触发AI/AO同步 (DI Trigger AIO)、DI触发AI (DI Trigger AI)、DI触发AO (DI Trigger AO)。

如果需要使用特殊模式下的模式, 用户需要确认购买设备是否支持该模式, 本设备支持的特殊模式如下表所示, 对应模式为绿色则支持, 红色则不支持; Customer是定制DAQ模式, 正常用户无法使用。如果模式配置错误, 会导致设备无法正常运行。

本设备支持的特殊模式:

| | |
|----------------------------------|-------------------------------------|
| ● AO-Sync-AI (DAQMode=1) | ● AI-Trigger-Encoder (DAQMode=2) |
| ● Encoder-Trigger-AI (DAQMode=3) | ● DI-Trigger-AI-Sync-AO (DAQMode=4) |
| ● DI-Trigger-AI (DAQMode=5) | ● DI-Trigger-AO (DAQMode=6) |

Config文本

MT-DAQ设备的开发和使用依赖于Config配置文本，只有正确配置该文本，才能保证设备的正常运行。不同型号的设备或板卡对应的配置参数是不同的。Python、LabVIEW和C#三种编程语言的Config配置文本完全相同。

通用Config配置文本通过MT-Master软件主页导出获得，用户可以根据实际设备或板卡的参数对配置文本进行修改配置，或者按照文本默认参数配置运行。

Config配置文本中的各项参数含义及其具体配置可以参考MT-DAQ上手指南，指南链接附于下文Support板块。

使用MT产品过程中如有任何疑问，可以通过访问官网：<http://www.mangotree.cn>联系专业客服咨询。



MangoTree官网

Support

MT-Master上手指南:

<https://server.mangotree.cn:9900/WebFile/Downloads/上手指南/MT-Master/>



Master上手指南

MT-Master视频教程:

<https://server.mangotree.cn:9900/WebFile/Downloads/视频教程/MT-Master/>



Master视频教程

MT-DAQ上手指南:

<https://server.mangotree.cn:9900/WebFile/Downloads/上手指南/MT-DAQ/>



DAQ上手指南

MT-DAQ视频教程:

<https://server.mangotree.cn:9900/WebFile/Downloads/视频教程/MT-DAQ/>



DAQ视频教程

MT-T564 Pinout

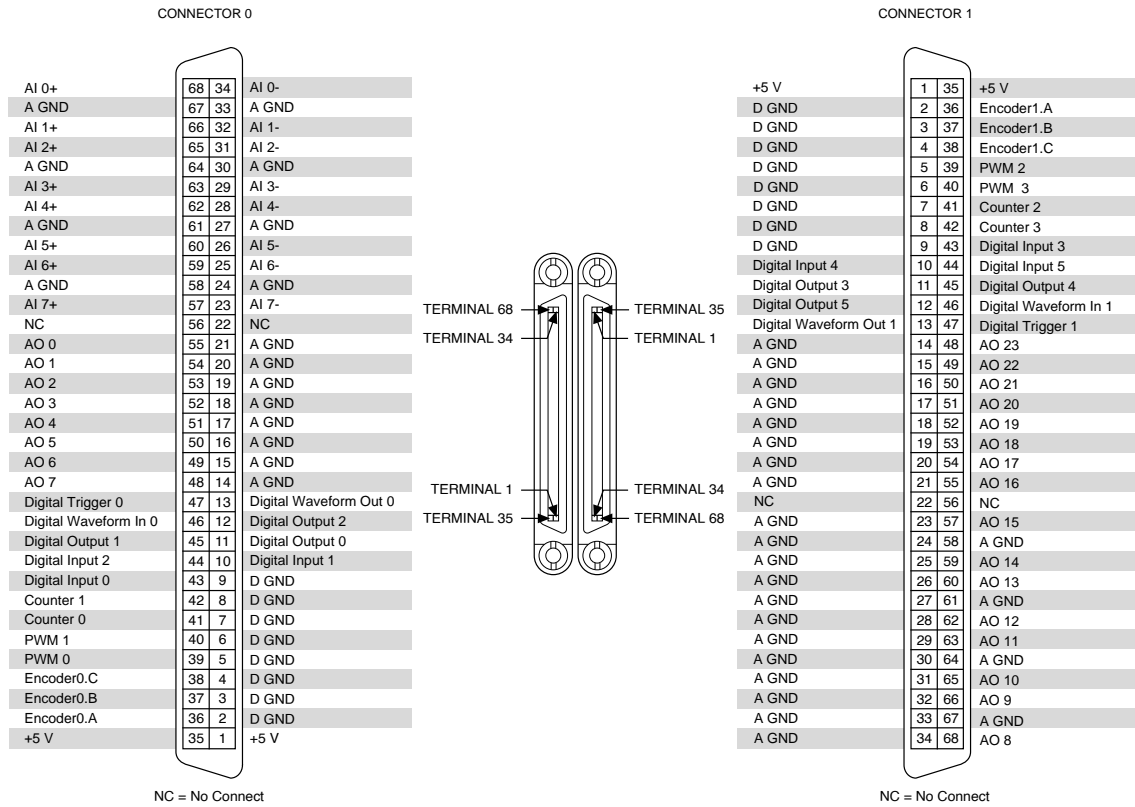

Dimensions

