

DataSheet

# MT-X313

## 2-Port Half-Duplex RS485/2-Port Full-Duplex RS422 Serial Module

This document contains the specifications for MT-X313. Specifications are typical at 25°C unless otherwise noted.



**Caution** Using the MT-X313 in a manner not described in this document may impair the protection the MT-X313 provides.

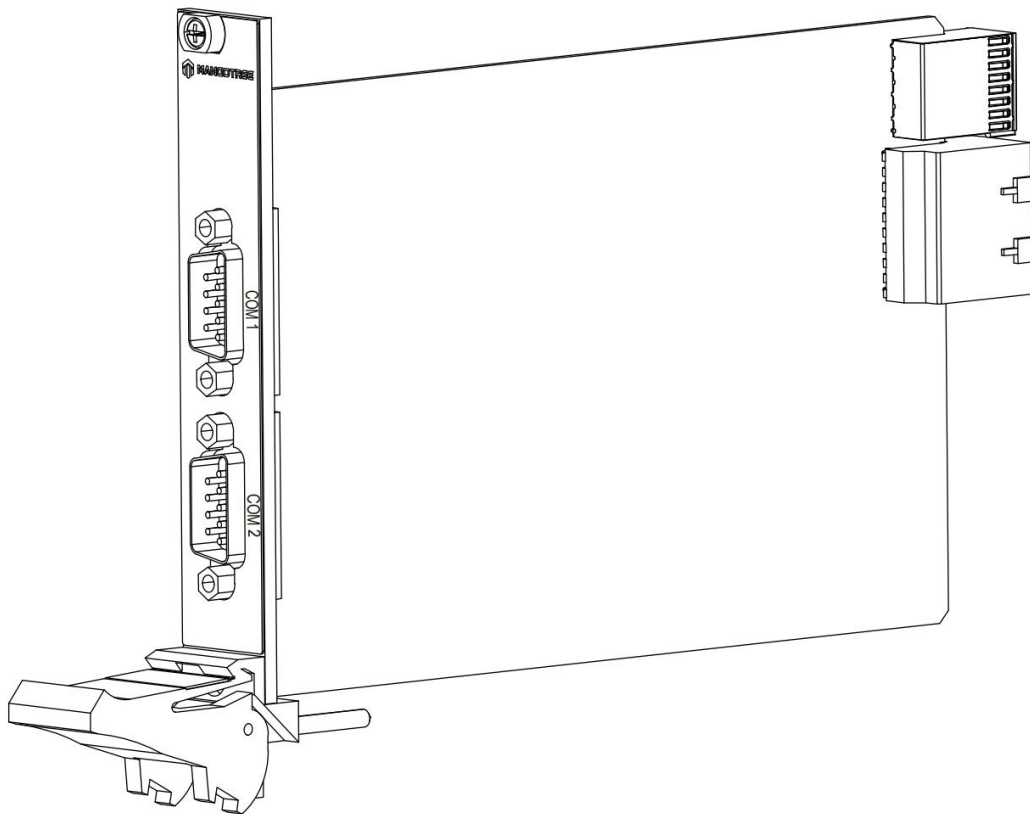

# MT-X313 Connectivity

---

Pin assignments for Connector1 and Connector2.

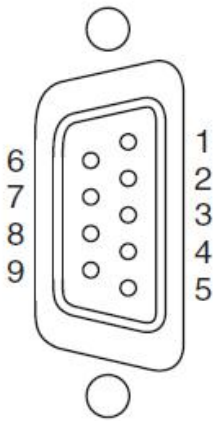
Connector	Pin	RS-422 Full Duplex	RS-485 Half Duplex
	1	TXD+	DATA+
	2	TXD-	DATA-
	3	RXD+	-
	4	RXD-	-
	5	GND	GND
	6	-	-
	7	-	-
	8	-	-
	9	-	-

## Hardware Overview

---

The MT-X313 has two independent RS485/RS422 ports that are isolated from the other modules in the system. Each port is fully compatible with the ANSI/EIA/TIA-485 standard.

## Characteristics

---

The following specifications are typical for the range -40 °C to 70 °C unless otherwise noted.

Maximum baud rate	115.2Kbps
Maximum cable length	1.2 km
Data line ESD protection	± 15kV (human body model)

## Power Requirements

Power consumption from chassis	500 mW max
Thermal dissipation (at 70 °C)	1500 mW max

# Safety Voltages

Connect only voltages that are within the following limits:

RS485/RS422 Port-to-COM -8 to +13 VDC max, Measurement Category I

---

## Isolation Voltages

---

### Port-to-earth ground

---

Continuous	60 VDC, Measurement Category I up to 5,000 m in altitude
------------	--

---

Withstand up to 2,000 m	1,000 Vrms, verified by a 5 s dielectric withstand test
-------------------------	---

---

Withstand up to 5,000 m	500 Vrms, verified by a 5 s dielectric withstand test
-------------------------	---

---

Measurement Category I is for measurements performed on circuits not directly connected to the electrical distribution system referred to as MAINS voltage. MAINS is a hazardous live electrical supply system that powers equipment. This category is for measurements of voltages from specially protected secondary circuits. Such voltage measurements include signal levels, special equipment, limited-energy parts of equipment, circuits powered by regulated low-voltage sources, and electronics.

## CE Compliance

This product meets the essential requirements of applicable European Directives, as follows:

- 2014/35/EU; Low-Voltage Directive (safety)
- 2014/30/EU; Electromagnetic Compatibility Directive (EMC)
- 2014/34/EU; Potentially Explosive Atmospheres (ATEX)

## Shock and Vibration

To meet these specifications, you must panel mount the system.

---

### Operating vibration

---

Random (IEC 60068-2-64)	5 g <sub>rms</sub> , 10 Hz to 500 Hz
-------------------------	--------------------------------------

---

Sinusoidal (IEC 60068-2-6)	5 g, 10 Hz to 500 Hz
Operating shock (IEC 60068-2-27)	30 g, 11 ms half sine; 50 g, 3 ms half sine; 18 shocks at 6 orientations

## Environmental

Refer to the manual for the chassis you are using for more information about meeting these specifications.

Operating temperature	-40 °C to 70 °C (IEC 60068-2-1, IEC 60068-2-2)
Storage temperature	-40 °C to 85 °C (IEC 60068-2-1, IEC 60068-2-2)
Ingress protection	IP40
Operating humidity (IEC 60068-2-78)	10% RH to 90% RH, noncondensing Storage
humidity (IEC 60068-2-78)	5% RH to 95% RH, noncondensing Pollution
Degree	2
Maximum altitude	5,000 m

Indoor use only.

# Config文本

MT-DAQ设备的开发和使用依赖于Config配置文本，只有正确配置该文本，才能保证设备的正常运行。不同型号的设备或板卡对应的配置参数是不同的。Python、LabVIEW和C#三种编程语言的Config配置文本完全相同。

通用Config配置文本通过MT-Master软件主页导出获得，用户可以根据实际设备或板卡的参数对配置文本进行修改配置，或者按照文本默认参数配置运行。

Config配置文本中的各项参数含义及其具体配置可以参考MT-DAQ上手指南，指南链接附于下文Support板块。

使用MT产品过程中如有任何疑问，可以通过访问官网：<http://www.mangotree.cn>联系专业客服咨询。



MangoTree官网

# Support

MT-Master上手指南:

<https://server.mangotree.cn:9900/WebFile/Downloads/上手指南/MT-Master/>



Master上手指南

MT-Master视频教程:

<https://server.mangotree.cn:9900/WebFile/Downloads/视频教程/MT-Master/>



Master视频教程

MT-DAQ上手指南:

<https://server.mangotree.cn:9900/WebFile/Downloads/上手指南/MT-DAQ/>



DAQ上手指南

MT-DAQ视频教程:

<https://server.mangotree.cn:9900/WebFile/Downloads/视频教程/MT-DAQ/>



DAQ视频教程

Dimensions:(mm)

