

DataSheet

MT-X522

This document contains the specifications for MT-X522. Specifications are typical at 25°C unless otherwise noted.



Caution Using the MT-X522 in a manner not described in this document may impair the protection the MT-X522 provides.

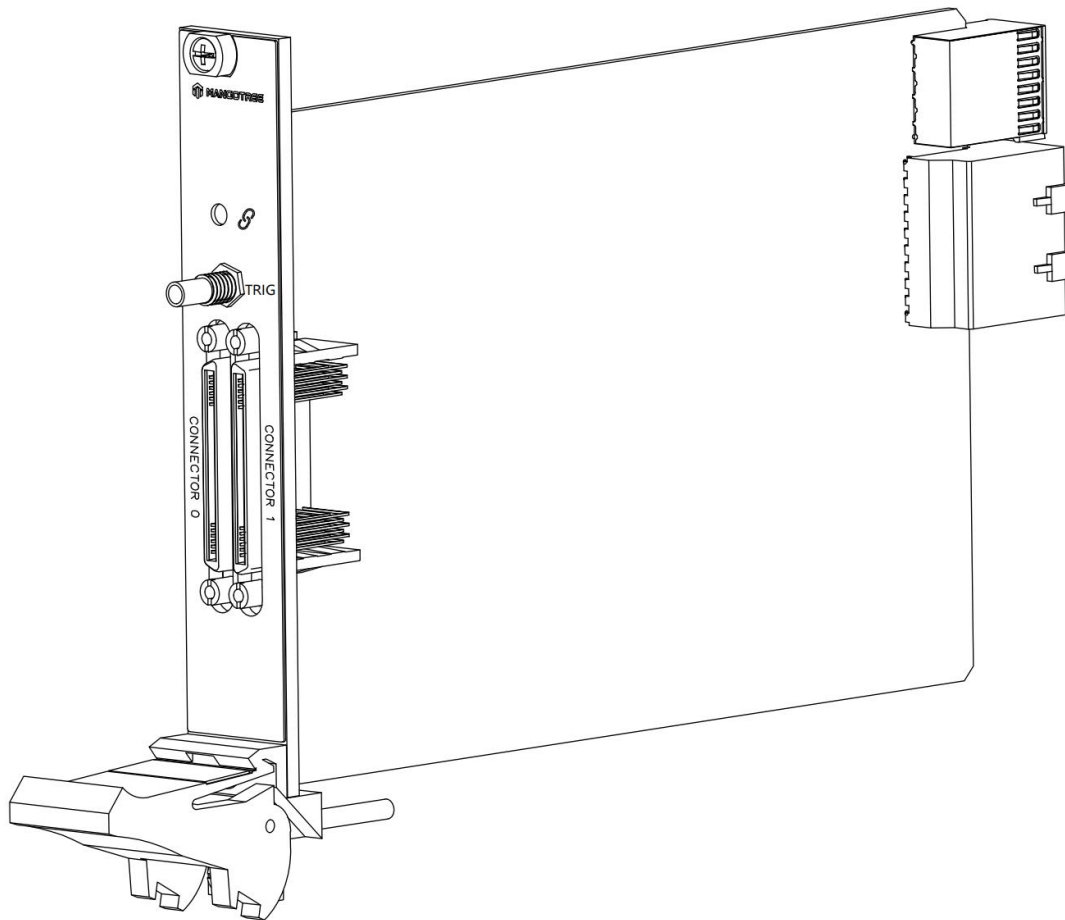

Analog Output

Number of channels	32
DAC resolution	16 bits
Type of DAC	String
Output voltage range	$\pm 10\text{V}$
Current drive	$\pm 10\text{ mA}$ per channel maximum
Output impedance	$375\ \Omega$
Sample rate	200KS/s maximum per channel

Table 1. Accuracy

Measurement Conditions		Percent of Reading (Gain Error)	Percent of Range (Offset Error)
Calibrated	Maximum (-40 °C to 70 °C)	0.214%	0.075%
	Typical (25 °C, $\pm 5\text{ °C}$)	0.010%	0.007%

Gain drift	$\pm 0.1\text{ ppm}/^\circ\text{C}$
Zero-code drift	$\pm 0.05\text{ ppm}/^\circ\text{C}$
Protection	
Overvoltage	$\pm 30\text{V}$
Short-circuit	Indefinitely
Noise	
Output noise	$10\text{nV} / \sqrt{\text{Hz}}$
Slew rate	$25\text{V}/\mu\text{s}$
Crosstalk	74dB
Capacitive drive	1nF
DNL	$\pm 1\text{ LSB}$ maximum
INL (endpoint)	$\pm 1\text{ LSB}$ maximum
External Digital Triggers	
Number of triggers	10
Source	TRIG,PXI_TRIG<0..7>,PXI_STAR

Maximum Power Requirements

Power requirements are dependent on the digital output loads and configuration of the LabVIEW FPGA VI used in your application.

+3.3V	1.23 A
-------	--------

+12 V	0.57 A
-------	--------

Physical Characteristics

Weight	200g
--------	------

Dimensions	See end of this document
------------	--------------------------

Safety Voltages

This product is designed to meet the requirements of the following electrical equipment safety standards for measurement, control, and laboratory use:

- IEC 61010-1, EN 61010-1
- UL 61010-1, CSA C22.2 No. 61010-1

CE Compliance

This product meets the essential requirements of applicable European Directives, as follows:

- 2014/35/EU; Low-Voltage Directive (safety)
- 2014/30/EU; Electromagnetic Compatibility Directive (EMC)
- 2014/34/EU; Potentially Explosive Atmospheres (ATEX)

Shock and Vibration

To meet these specifications, you must panel mount the system.

Operating vibration

Random (IEC 60068-2-64)	5 g _{rms} , 10 Hz to 500 Hz
-------------------------	--------------------------------------

Sinusoidal (IEC 60068-2-6)	5 g, 10 Hz to 500 Hz
----------------------------	----------------------

Operating shock (IEC 60068-2-27)	30 g, 11 ms half sine; 50 g, 3 ms half sine;
----------------------------------	--

Environmental

Refer to the manual for the chassis you are using for more information about meeting these specifications.

Operating temperature	-40 °C to 70 °C (IEC 60068-2-1, IEC 60068-2-2)
Storage temperature	-40 °C to 85 °C (IEC 60068-2-1, IEC 60068-2-2)
Ingress protection	IP40
Operating humidity (IEC 60068-2-78)	10% RH to 90% RH, noncondensing Storage
humidity (IEC 60068-2-78)	5% RH to 95% RH, noncondensing Pollution
Degree	2
Maximum altitude	4,000 m

Indoor use only.

DAQMode Support

通用模式 (DAQMode=0) 包括: AI、AO、Counter、PWM、Encoder、Digital Input、Digital Output、Digital Waveform Input、Digital Waveform Output、Temperature。

通用模式适用所有的MT-DAQ设备, 该模式下用户可以开发使用设备数据手册中说明的全部功能, 不同设备支持的功能不同。本设备通用模式支持的功能如下表所示, 对应功能为绿色则支持, 红色则不支持。

本设备通用模式 (DAQMode=0) 支持的功能:

● AI	● AO
● Counter	● PWM
● Encoder	● Temperature
● Digital Input	● Digital Output
● Digital Waveform Input	● Digital Waveform Output

特殊模式包括: AI/AO同步 (AIO Sync)、编码器触发AI (Encoder Trigger AI)、AI触发编码器 (AI Trigger Encoder)、DI触发AI/AO同步 (DI Trigger AIO)、DI触发AI (DI Trigger AI)、DI触发AO (DI Trigger AO)。

如果需要使用特殊模式下的模式, 用户需要确认购买设备是否支持该模式, 本设备支持的特殊模式如下表所示, 对应模式为绿色则支持, 红色则不支持; Customer是定制DAQ模式, 正常用户无法使用。如果模式配置错误, 会导致设备无法正常运行。

本设备支持的特殊模式:

● AO-Sync-AI (DAQMode=1)	● AI-Trigger-Encoder (DAQMode=2)
● Encoder-Trigger-AI (DAQMode=3)	● DI-Trigger-AI-Sync-AO (DAQMode=4)
● DI-Trigger-AI (DAQMode=5)	● DI-Trigger-AO (DAQMode=6)

Config文本

MT-DAQ设备的开发和使用依赖于Config配置文本，只有正确配置该文本，才能保证设备的正常运行。不同型号的设备或板卡对应的配置参数是不同的。Python、LabVIEW和C#三种编程语言的Config配置文本完全相同。

通用Config配置文本通过MT-Master软件主页导出获得，用户可以根据实际设备或板卡的参数对配置文本进行修改配置，或者按照文本默认参数配置运行。

Config配置文本中的各项参数含义及其具体配置可以参考MT-DAQ上手指南，指南链接附于下文Support板块。

使用MT产品过程中如有任何疑问，可以通过访问官网：<http://www.mangotree.cn>联系专业客服咨询。



MangoTree官网

Support

MT-Master上手指南:

<https://server.mangotree.cn:9900/WebFile/Downloads/上手指南/MT-Master/>



Master上手指南

MT-Master视频教程:

<https://server.mangotree.cn:9900/WebFile/Downloads/视频教程/MT-Master/>



Master视频教程

MT-DAQ上手指南:

<https://server.mangotree.cn:9900/WebFile/Downloads/上手指南/MT-DAQ/>



DAQ上手指南

MT-DAQ视频教程:

<https://server.mangotree.cn:9900/WebFile/Downloads/视频教程/MT-DAQ/>



DAQ视频教程

MT-X522 Pinout

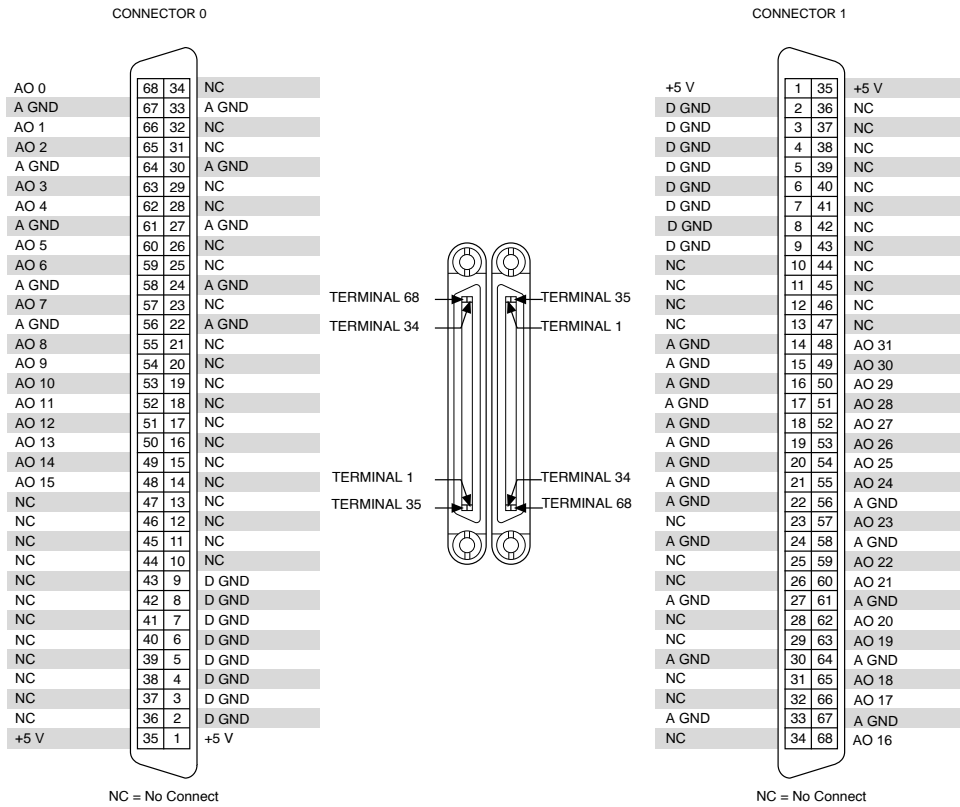

Dimensions:(mm)

