

DataSheet

MT-X613

4 AI, ± 10 V, 32 bit, 204.8kS/s/ch Simultaneous
1 Trigger

This document contains the specifications for MT-X613. Specifications are typical at 25°C unless otherwise noted.



Caution Using the MT-X613 in a manner not described in this document may impair the protection the MT-X613 provides.

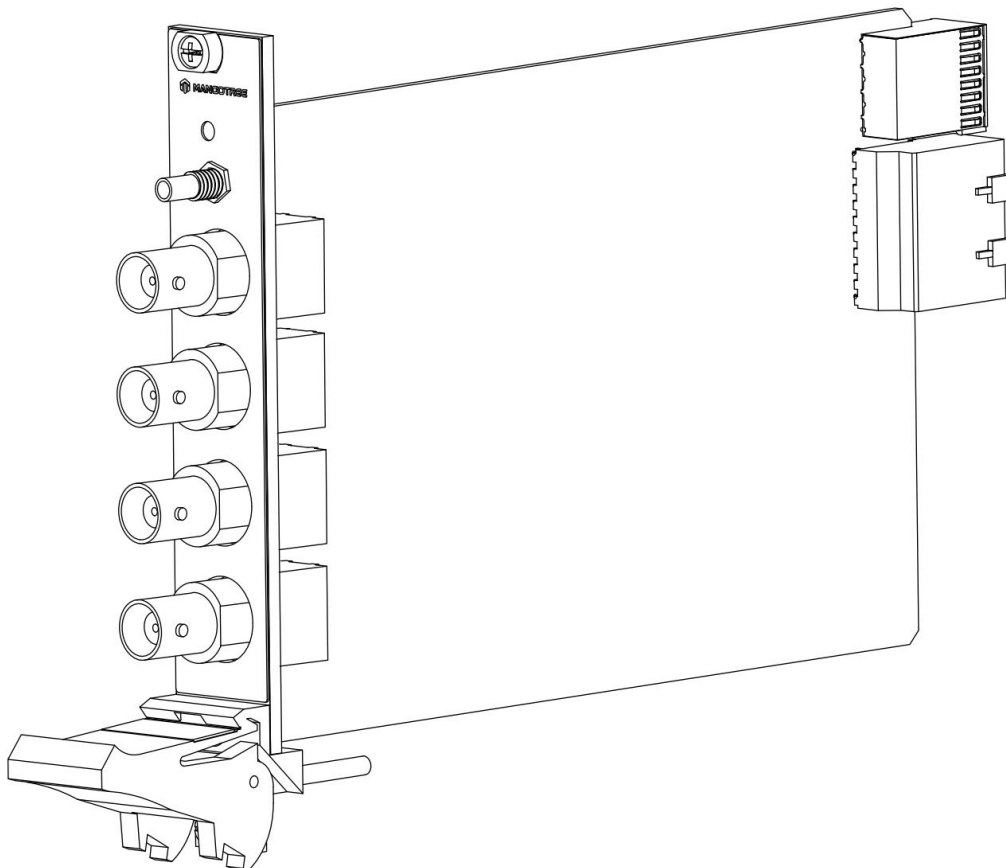

Input Characteristics

Number of channels	4 differential input channels
ADC resolution	32bits
Sampling mode	Simultaneous
Support Sample rate	204.8kS/s、 192kS/s、 102.4kS/s、 96kS/s
Input coupling	AC/DC(hardware-selectable)
Input range	$\pm 10V$
AC voltage full-scale range	
Minimum	$\pm 10V_{pk}$
Typical	$\pm 10.05V_{pk}$
Maximum	$\pm 10.15V_{pk}$
IEPE excitation current	
Minimum	2.0 mA
Typical	2.1 mA
IEPE compliance voltage	24V maximum
Crosstalk (1 kHz)	$> 110dB$
Differential input impedance	22k Ω
Signal-to-noise ratio(SNR)	$> 120dB$
Frequency response	$\pm 0.1dB@20Hz\sim 20kHz$
Total harmonic distortion(THD)	-115dB
Total harmonic distortion+Noise(THD+N)	-110dB

Table 1. AI Idle Channel Noise

Sample Rate (kS/s)	Idle Channel Noise	
	dBV _{rms}	uV _{rms}
51.2 kS/s	-117.9 dBV _{rms}	9 uV _{rms}
102.4kS/s	-114.7 dBV _{rms}	13 uV _{rms}
204.8kS/s	-112.3 dBV _{rms}	17 uV _{rms}

Table 2. AC/DC Configuration

Configuration	Dial Switch	
	S1	S2
DC Coupling	ON	OFF
AC Coupling	OFF	OFF
AC Coupling with IEPE	OFF	ON

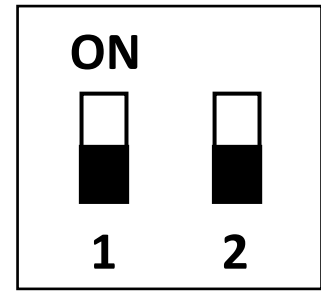
**Table 3. Accuracy**

Measurement Conditions		Percent of Reading (Gain Error)	Percent of Range (Offset Error)
Calibrated	Maximum (-40 °C to 70 °C)	0.034%	±0.014%
	Typical (25 °C ±5 °C)	0.007%	±0.005%

External Digital Triggers

Number of triggers	10
Source	TRIG, PXI_TRIG<0..7>, PXI_STAR

Power Requirements

Power consumption from chassis: 900mW maximum

Thermal dissipation (at 70 °C) 930mW maximum

Safety Voltages

Connect only voltages that are within the following limits:

Channel-to-earth ground ±30 V maximum, Measurement Category I

Isolation

Channel-to-channel None

Channel-to-earth ground None

Measurement Category I is for measurements performed on circuits not directly connected to the electrical distribution system referred to as MAINS voltage. MAINS is a hazardous live electrical supply system that powers equipment. This category is for measurements of voltages from specially protected secondary circuits. Such voltage measurements include signal levels, special equipment, limited-energy parts of equipment, circuits powered by regulated low-voltage sources, and electronics.

CE Compliance

This product meets the essential requirements of applicable European Directives, as follows:

2014/35/EU; Low-Voltage Directive (safety)

2014/30/EU; Electromagnetic Compatibility Directive (EMC)

2014/34/EU; Potentially Explosive Atmospheres (ATEX)

Shock and Vibration

To meet these specifications, you must panel mount the system.

Operating vibration

Random (IEC 60068-2-64)	5 g _{rms} , 10 Hz to 500 Hz
Sinusoidal (IEC 60068-2-6)	5 g, 10 Hz to 500 Hz
Operating shock (IEC 60068-2-27)	30 g, 11 ms half sine; 50 g, 3 ms half sine; 18 shocks at 6 orientations

Environmental

Refer to the manual for the chassis you are using for more information about meeting these specifications.

Operating temperature	-40 °C to 70 °C (IEC 60068-2-1, IEC 60068-2-2)
Storage temperature	-40 °C to 85 °C (IEC 60068-2-1, IEC 60068-2-2)
Ingress protection	IP40
Operating humidity (IEC 60068-2-78)	10% RH to 90% RH, noncondensing Storage
humidity (IEC 60068-2-78)	5% RH to 95% RH, noncondensing Pollution
Degree	2
Maximum altitude	500 m

Indoor use only.

DAQMode Support

通用模式 (DAQMode=0) 包括: AI、AO、Counter、PWM、Encoder、Digital Input、Digital Output、Digital Waveform Input、Digital Waveform Output、Temperature。

通用模式适用所有的MT-DAQ设备, 该模式下用户可以开发使用设备数据手册中说明的全部功能, 不同设备支持的功能不同。本设备通用模式支持的功能如下表所示, 对应功能为绿色则支持, 红色则不支持。

本设备通用模式 (DAQMode=0) 支持的功能:

● AI	● AO
● Counter	● PWM
● Encoder	● Temperature
● Digital Input	● Digital Output
● Digital Waveform Input	● Digital Waveform Output

特殊模式包括: AI/AO同步 (AIO Sync)、编码器触发AI (Encoder Trigger AI)、AI触发编码器 (AI Trigger Encoder)、DI触发AI/AO同步 (DI Trigger AIO)、DI触发AI (DI Trigger AI)、DI触发AO (DI Trigger AO)。

如果需要使用特殊模式下的模式, 用户需要确认购买设备是否支持该模式, 本设备支持的特殊模式如下表所示, 对应模式为绿色则支持, 红色则不支持; Customer是定制DAQ模式, 正常用户无法使用。如果模式配置错误, 会导致设备无法正常运行。

本设备支持的特殊模式:

● AO-Sync-AI (DAQMode=1)	● AI-Trigger-Encoder (DAQMode=2)
● Encoder-Trigger-AI (DAQMode=3)	● DI-Trigger-AI-Sync-AO (DAQMode=4)
● DI-Trigger-AI (DAQMode=5)	● DI-Trigger-AO (DAQMode=6)

Config文本

MT-DAQ设备的开发和使用依赖于Config配置文本，只有正确配置该文本，才能保证设备的正常运行。不同型号的设备或板卡对应的配置参数是不同的。Python、LabVIEW和C#三种编程语言的Config配置文本完全相同。

通用Config配置文本通过MT-Master软件主页导出获得，用户可以根据实际设备或板卡的参数对配置文本进行修改配置，或者按照文本默认参数配置运行。

Config配置文本中的各项参数含义及其具体配置可以参考MT-DAQ上手指南，指南链接附于下文Support板块。

使用MT产品过程中如有任何疑问，可以通过访问官网：<http://www.mangotree.cn>联系专业客服咨询。



MangoTree官网

Support

MT-Master上手指南:

<https://server.mangotree.cn:9900/WebFile/Downloads/上手指南/MT-Master/>



Master上手指南

MT-Master视频教程:

<https://server.mangotree.cn:9900/WebFile/Downloads/视频教程/MT-Master/>



Master视频教程

MT-DAQ上手指南:

<https://server.mangotree.cn:9900/WebFile/Downloads/上手指南/MT-DAQ/>



DAQ上手指南

MT-DAQ视频教程:

<https://server.mangotree.cn:9900/WebFile/Downloads/视频教程/MT-DAQ/>



DAQ视频教程

Dimensions:(mm)

