

DataSheet

# MT-X920

R Series Reconfigurable I/O Module(AI,AO,DIO),8 AI, 8 AO,  
64 DIO, 1MS/s AIO, Kintex-7 325T FPGA

This document contains the specifications for MT-X920.Specifications are typical at 25°C unless otherwise noted.



**Caution** Using the MT-X920 in a manner not described in this document may impair the protection the MT-X920 provides.

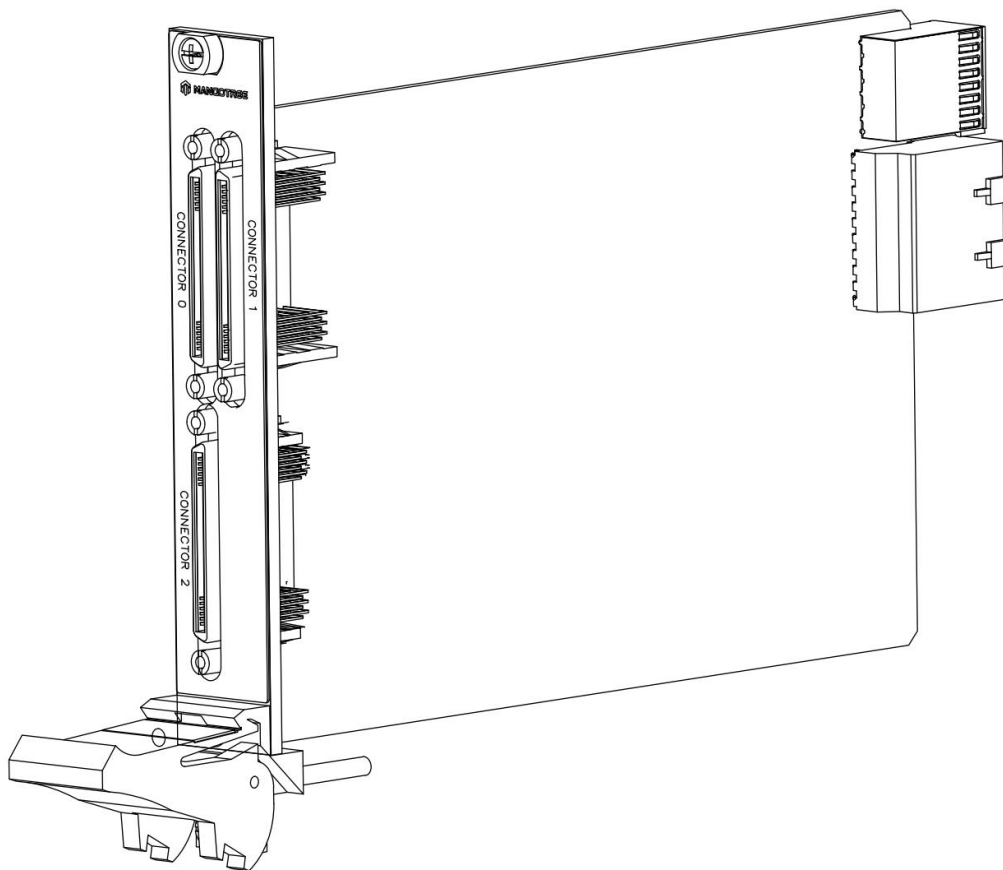

# Analog Input

Number of channels	8
ADC resolution	16 bits
Type of ADC	Successive approximation register (SAR)
Input range	±10V
Input Voltage Ranges	
Measurement Voltage(AI+ to AI-)	
Minimum(V)	±10.2V
Typical(V)	±10.4V
Maximum	±10.6V
Overvoltage protection	±30 V
Conversion time	1 µs minimum
Sample rate	1 MS/s maximum per channel

**Table 1.** Accuracy

Measurement Conditions		Percent of Reading (Gain Error)	Percent of Range (Offset Error)
Calibrated	Maximum (-40 °C to 70 °C)	0.142%	±0.070%
	Typical (23 °C ±5 °C)	0.010%	±0.007%

CMRR	120 dB minimum
-3 dB bandwidth	>15 kHz
Input impedance	1MΩ
Crosstalk	-90 dB
Total Harmonic Distortion(THD)	-107dB
No missing codes	16 bits
DNL	±0.4LSB
INL	±0.5LSB
SNR	90 dB

## Analog Output

Number of channels	8
DAC resolution	16 bits
Type of DAC	String
Output voltage range	$\pm 10\text{V}$
Current drive	$\pm 10\text{ mA}$ per channel maximum
Output impedance	$375\ \Omega$
Sample rate	1 MS/s maximum per channel

**Table 2.** Accuracy

Measurement Conditions		Percent of Reading (Gain Error)	Percent of Range (Offset Error)
Calibrated	Maximum (-40 °C to 70 °C)	0.214%	0.075%
	Typical (25 °C, $\pm 5\text{ °C}$ )	0.010%	0.007%

Gain drift	$\pm 0.1\text{ ppm}/^\circ\text{C}$
Zero-code drift	$\pm 0.05\text{ ppm}/^\circ\text{C}$
Protection	
Overvoltage	$\pm 30\text{V}$
Short-circuit	Indefinitely
Noise	
Output noise	$10\text{nV} / \sqrt{\text{Hz}}$
Slew rate	$25\text{V}/\mu\text{s}$
Crosstalk	74dB
Capacitive drive	1nF
DNL	$\pm 1\text{ LSB}$ maximum
INL (endpoint)	$\pm 1\text{ LSB}$ maximum

# Digital I/O

---

**Table 3.** Channel Frequency

Connector	Number of Channels	Maximum Frequency
Connector 0	16	80 MHz
Connector 1	16	80 MHz
Connector 2	32	80 MHz

Compatibility LVTTL, LVCOMS

---

Logic family Fixed

---

Voltage level 3.3V

---

**Table 4.** Digital Output Logic Levels

Logic Family	Current	Output Low Voltage(VoL)	Output High Voltage(VoH)
		Maximum	Maximum
3.3V	100uA	0.20 V	3.00 V
	4mA	0.40 V	2.40 V

Maximum DC output current per channel

---

Source 4.0 mA

---

Sink 4.0 mA

---

Output impedance 50  $\Omega$

---

Direction control of digital I/O channels Per Channel

---

Minimum I/O pulse width 6.25 ns

---

Minimum sampling period 5 ns

---

**Table 5.** Digital Input Logic Levels

Logic Family	Input Low Voltage(VIL)	Input High Voltage(VIH)
	Maximum	Maximum
3.3V	0.80 V	2.00 V

Minimum input	-0.3 V
Maximum input	3.6V
Input leakage current	± 15uA maximum
Input impedance	50kΩ typical, pull-down

## Reconfigurable FPGA

FPGA type	Kintex-7 325T
Number of flip-flops	407,600
Number of LUTs	203,800
Embedded Block RAM	16,020 kbits
Number of DSP48 slices	840

## Maximum Power Requirements

Power requirements are dependent on the digital output loads and configuration of the LabVIEW FPGA VI used in your application.

+3.3V	3 A
+12 V	2 A

## Safety Voltages

This product is designed to meet the requirements of the following electrical equipment safety standards for measurement, control, and laboratory use:

- IEC 61010-1, EN 61010-1
- UL 61010-1, CSA C22.2 No. 61010-1

## CE Compliance

This product meets the essential requirements of applicable European Directives, as follows:

- 2014/35/EU; Low-Voltage Directive (safety)
- 2014/30/EU; Electromagnetic Compatibility Directive (EMC)

- 2014/34/EU; Potentially Explosive Atmospheres (ATEX)

## Shock and Vibration

To meet these specifications, you must panel mount the system.

### Operating vibration

Random (IEC 60068-2-64)	5 g <sub>rms</sub> , 10 Hz to 500 Hz
Sinusoidal (IEC 60068-2-6)	5 g, 10 Hz to 500 Hz
Operating shock (IEC 60068-2-27)	30 g, 11 ms half sine; 50 g, 3 ms half sine; 18 shocks at 6 orientations

## Environmental

Refer to the manual for the chassis you are using for more information about meeting these specifications.

Operating temperature	-40 °C to 70 °C (IEC 60068-2-1, IEC 60068-2-2)
Storage temperature	-40 °C to 85 °C (IEC 60068-2-1, IEC 60068-2-2)
Ingress protection	IP40
Operating humidity (IEC 60068-2-78)	10% RH to 90% RH, noncondensing Storage
humidity (IEC 60068-2-78)	5% RH to 95% RH, noncondensing Pollution
Degree	2
Maximum altitude	4,000 m

Indoor use only.

# Support

MT-Master上手指南:

<https://server.mangotree.cn:9900/WebFile/Downloads/上手指南/MT-Master/>

MT-Master视频教程:

<https://server.mangotree.cn:9900/WebFile/Downloads/视频教程/MT-Master/>



Master上手指南



Master视频教程

MT-RIO上手指南:

<https://server.mangotree.cn:9900/WebFile/Downloads/上手指南/MT-RIO/>

MT-RIO视频教程:

<https://server.mangotree.cn:9900/WebFile/Downloads/视频教程/MT-RIO/>



RIO上手指南



RIO视频教程

MT-Veristand上手指南:

<https://server.mangotree.cn:9900/WebFile/Downloads/上手指南/MT-VeriStand/>

MT-Veristand视频教程:

<https://server.mangotree.cn:9900/WebFile/Downloads/视频教程/MT-VeriStand/>



VeriStand上手指南



VeriStand视频教程

# MT-X920 Pinout

CONNECTOR 0

AI 0+	68	34	AI 0-
A GND	67	33	A GND
AI 1+	66	32	AI 1-
AI 2+	65	31	AI 2-
A GND	64	30	A GND
AI 3+	63	29	AI 3-
AI 4+	62	28	AI 4-
A GND	61	27	A GND
AI 5+	60	26	AI 5-
AI 6+	59	25	AI 6-
A GND	58	24	A GND
AI 7+	57	23	AI 7-
NC	56	22	NC
AO 0	55	21	A GND
AO 1	54	20	A GND
AO 2	53	19	A GND
AO 3	52	18	A GND
AO 4	51	17	A GND
AO 5	50	16	A GND
AO 6	49	15	A GND
AO 7	48	14	A GND
DIO 15	47	13	DIO 14
DIO 13	46	12	DIO 12
DIO 11	45	11	DIO 10
DIO 9	44	10	DIO 8
DIO 7	43	9	D GND
DIO 6	42	8	D GND
DIO 5	41	7	D GND
DIO 4	40	6	D GND
DIO 3	39	5	D GND
DIO 2	38	4	D GND
DIO 1	37	3	D GND
DIO 0	36	2	D GND
+5 V	35	1	+5 V

NC = No Connect

CONNECTOR 1

+5 V	1	35	+5 V
D GND	2	36	DIO 0
D GND	3	37	DIO 1
D GND	4	38	DIO 2
D GND	5	39	DIO 3
D GND	6	40	DIO 4
D GND	7	41	DIO 5
D GND	8	42	DIO 6
D GND	9	43	DIO 7
DIO 8	10	44	DIO 9
DIO 10	11	45	DIO 11
DIO 12	12	46	DIO 13
DIO 14	13	47	DIO 15
NC	14	48	NC
NC	15	49	NC
NC	16	50	NC
NC	17	51	NC
NC	18	52	NC
NC	19	53	NC
NC	20	54	NC
NC	21	55	NC
NC	22	56	NC
NC	23	57	NC
NC	24	58	NC
NC	25	59	NC
NC	26	60	NC
NC	27	61	NC
NC	28	62	NC
NC	29	63	NC
NC	30	64	NC
NC	31	65	NC
NC	32	66	NC
NC	33	67	NC
NC	34	68	NC

NC = No Connect

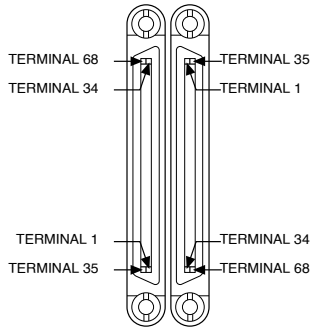

CONNECTOR 2

D GND	68	34	D GND
NC	67	33	D GND
D GND	66	32	D GND
DIO 0	65	31	DIO 1
D GND	64	30	D GND
DIO 2	63	29	DIO 3
D GND	62	28	D GND
DIO 4	61	27	DIO 5
D GND	60	26	D GND
DIO 6	59	25	DIO 7
D GND	58	24	D GND
DIO 8	57	23	DIO 9
D GND	56	22	D GND
DIO 10	55	21	DIO 11
D GND	54	20	D GND
DIO 12	53	19	DIO 13
D GND	52	18	D GND
DIO 14	51	17	DIO 15
D GND	50	16	D GND
DIO 16	49	15	DIO 17
D GND	48	14	D GND
DIO 18	47	13	DIO 19
D GND	46	12	D GND
DIO 20	45	11	DIO 21
D GND	44	10	D GND
DIO 22	43	9	DIO 23
D GND	42	8	D GND
DIO 24	41	7	DIO 25
D GND	40	6	D GND
DIO 26	39	5	DIO 27
D GND	38	4	D GND
DIO 28	37	3	DIO 29
D GND	36	2	D GND
DIO 30	35	1	DIO 31

NC = No Connect

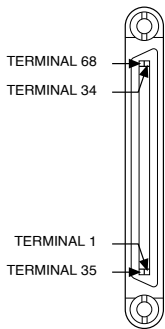



Dimensions:(mm)

