

## DataSheet

# MT-X732

Multiplexer module, 2-wire, 16×1,2 banks, 250VAC/220VDC, 2A

This document contains the specifications for MT-X732. Specifications are typical at 25°C unless otherwise noted.



**Caution** Using the MT-X732 in a manner not described in this document may impair the protection the MT-X732 provides.

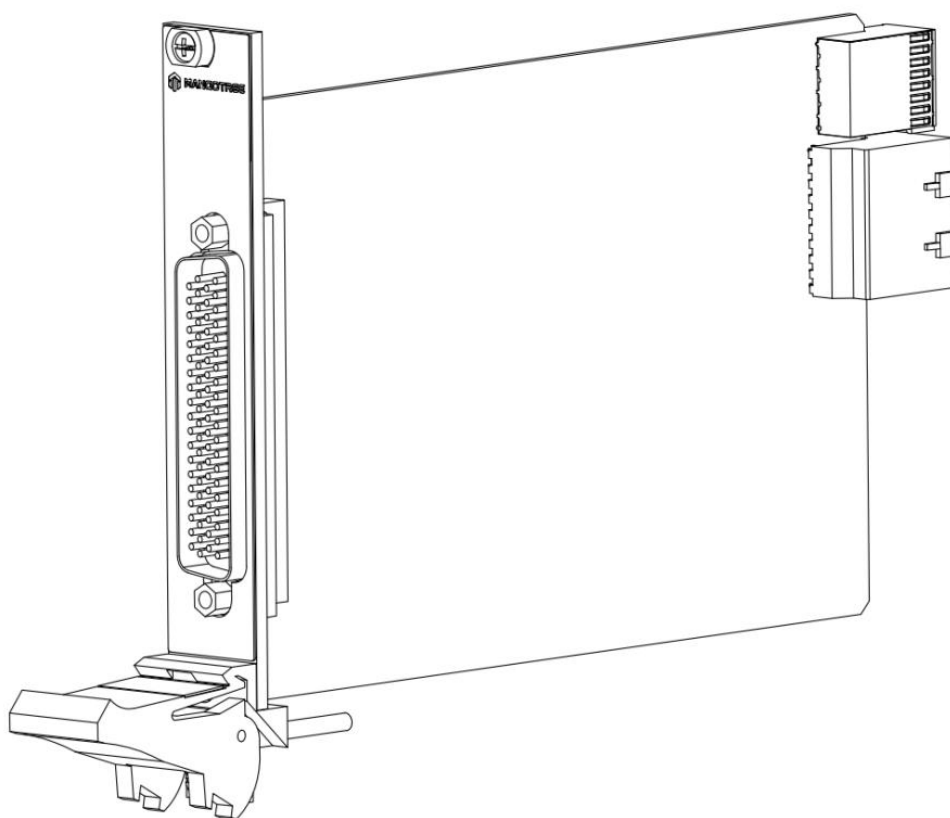

# MT-X732 Connectivity

Pin definition of DSUB connector.

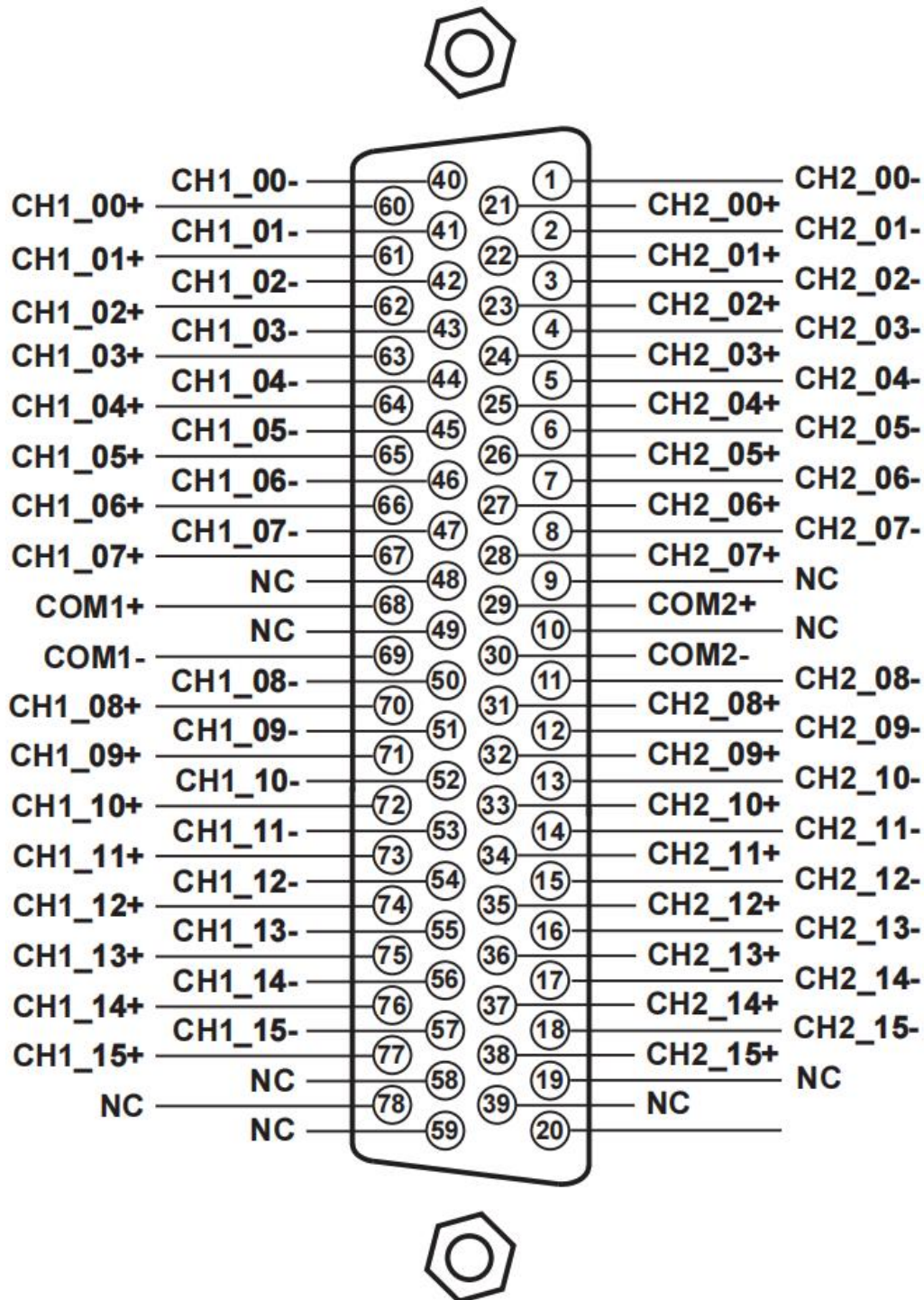

# Hardware Diagram

---

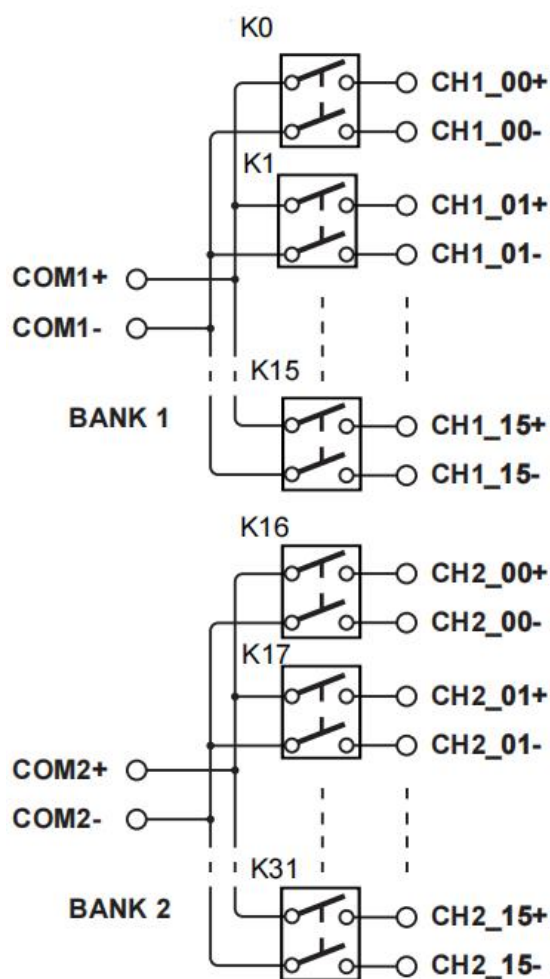

## MT-X732 Specifications

---

Specifications are valid at 23 °C unless otherwise noted.

### Input Characteristics

Number of channels	32
Topology	2-wire, 16×1, 2 banks
Maximum switching voltage	220V DC, 250V AC
Maximum switching power (per channel)	
AC	62.5 VA
DC (30 V to 220 V)	60 W

Maximum current (per channel)	2 A
DC path resistance	
Initial	<0.8 $\Omega$
End-of-life	$\geq 1.8 \Omega$
Relay operate time	
Typical	3 ms
Maximum	6 ms

## Safety Voltages

This product is designed to meet the requirements of the following electrical equipment safety standards for measurement, control, and laboratory use:

- IEC 61010-1, EN 61010-1
- UL 61010-1, CSA C22.2 No. 61010-1

## CE Compliance

This product meets the essential requirements of applicable European Directives, as follows:

- 2014/35/EU; Low-Voltage Directive (safety)
- 2014/30/EU; Electromagnetic Compatibility Directive (EMC)
- 2014/34/EU; Potentially Explosive Atmospheres (ATEX)

## Shock and Vibration

To meet these specifications, you must panel mount the system.

Random vibration	
Operating (IEC 60068-2-64)	0.3g <sub>rms</sub> , 5 Hz to 500 Hz
Nonoperating (IEC 60068-2-6)	2.4g <sub>rms</sub> , 5 Hz to 500 Hz
Operating shock (IEC 60068-2-27)	30 g, 11 ms half sine;

# Environmental

Refer to the manual for the chassis you are using for more information about meeting these specifications.

Operating temperature	0 °C to 55 °C
Storage temperature	-20°C to 70 °C
Operating humidity (IEC 60068-2-78)	10% RH to 90% RH, noncondensing
Storage humidity (IEC 60068-2-78)	5% RH to 95% RH, noncondensing Pollution
Degree	2
Maximum altitude	2,000 m

## Config文本

MT-DAQ设备的开发和使用依赖于Config配置文本，只有正确配置该文本，才能保证设备的正常运行。不同型号的设备或板卡对应的配置参数是不同的。Python、LabVIEW和C#三种编程语言的Config配置文本完全相同。

通用Config配置文本通过MT-Master软件主页导出获得，用户可以根据实际设备或板卡的参数对配置文本进行修改配置，或者按照文本默认参数配置运行。

Config配置文本中的各项参数含义及其具体配置可以参考MT-DAQ上手指南，指南链接附于下文Support板块。

使用MT产品过程中如有任何疑问，可以通过访问官网：<http://www.mangotree.cn>联系专业客服咨询。



MangoTree官网

# Support

MT-Master上手指南:

<http://server.mangotree.cn:9900/WebFile/Downloads/上手指南/MT-Master/>



Master上手指南

MT-Master视频教程:

<http://server.mangotree.cn:9900/WebFile/Downloads/视频教程/MT-Master/>



Master视频教程

MT-DAQ上手指南:

<http://server.mangotree.cn:9900/WebFile/Downloads/上手指南/MT-DAQ/>



DAQ上手指南

MT-DAQ视频教程:

<http://server.mangotree.cn:9900/WebFile/Downloads/视频教程/MT-DAQ/>



DAQ视频教程

