

DataSheet

MT-X745

Matrix module, 1-wire, 4×12, 2 banks, 250VAC/220VDC, 2A

This document contains the specifications for MT-X745. Specifications are typical at 25°C unless otherwise noted.



Caution Using the MT-X745 in a manner not described in this document may impair the protection the MT-X745 provides.

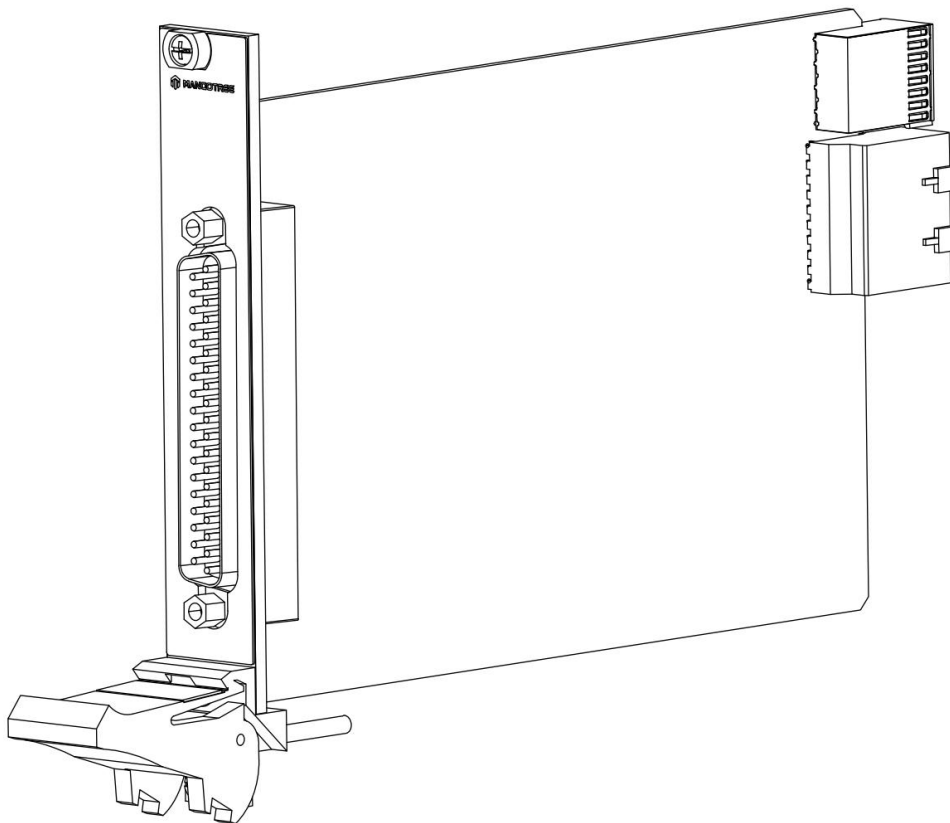

MT-X745 Connectivity

Pin definition of DSUB connector.

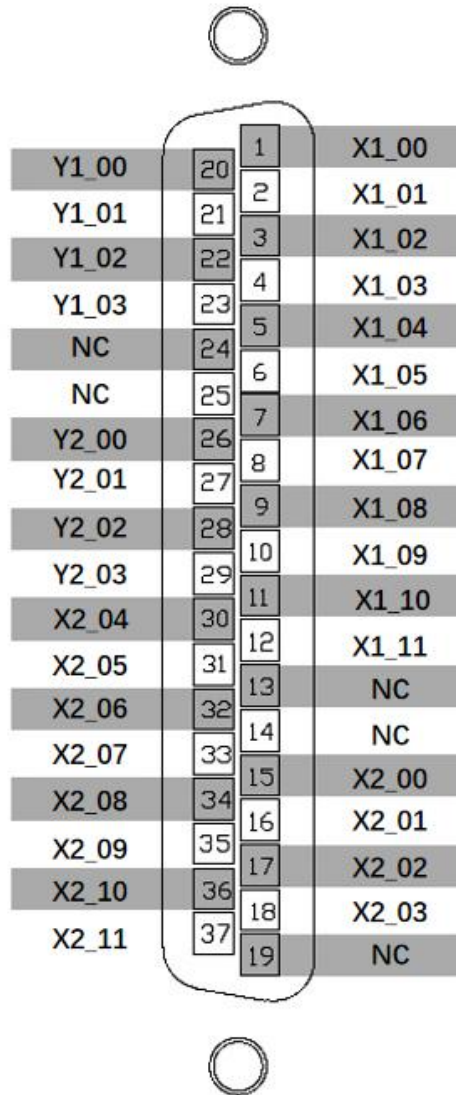

Hardware Diagram

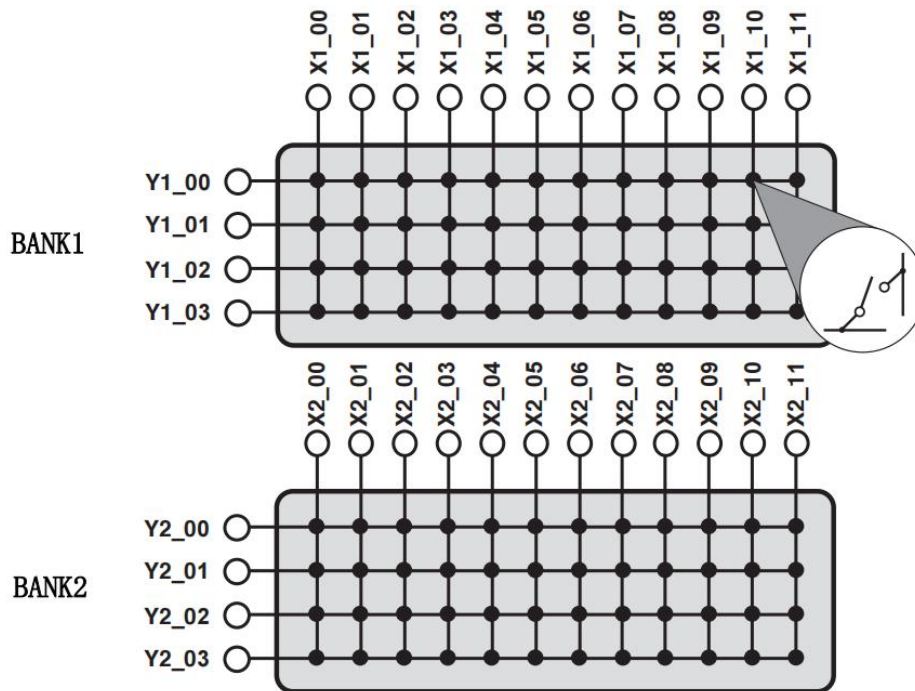

NO.	Signal Path	Relay Number	NO.	Signal Path	Relay Number
1	Y1_00 to X1_00	K0	49	Y2_00 to X2_00	K48
2	Y1_00 to X1_01	K1	50	Y2_00 to X2_01	K49
3	Y1_00 to X1_02	K2	51	Y2_00 to X2_02	K50
4	Y1_00 to X1_03	K3	52	Y2_00 to X2_03	K51
5	Y1_00 to X1_04	K4	53	Y2_00 to X2_04	K52
6	Y1_00 to X1_05	K5	54	Y2_00 to X2_05	K53
7	Y1_00 to X1_06	K6	55	Y2_00 to X2_06	K54
8	Y1_00 to X1_07	K7	56	Y2_00 to X2_07	K55
9	Y1_00 to X1_08	K8	57	Y2_00 to X2_08	K56
10	Y1_00 to X1_09	K9	58	Y2_00 to X2_09	K57
11	Y1_00 to X1_10	K10	59	Y2_00 to X2_10	K58
12	Y1_00 to X1_11	K11	60	Y2_00 to X2_11	K59
13	Y1_01 to X1_00	K12	61	Y2_01 to X2_00	K60
14	Y1_01 to X1_01	K13	62	Y2_01 to X2_01	K61
15	Y1_01 to X1_02	K14	63	Y2_01 to X2_02	K62
16	Y1_01 to X1_03	K15	64	Y2_01 to X2_03	K63
17	Y1_01 to X1_04	K16	65	Y2_01 to X2_04	K64

18	Y1_01 to X1_05	K17	66	Y2_01 to X2_05	K65
19	Y1_01 to X1_06	K18	67	Y2_01 to X2_06	K66
20	Y1_01 to X1_07	K19	68	Y2_01 to X2_07	K67
21	Y1_01 to X1_08	K20	69	Y2_01 to X2_08	K68
22	Y1_01 to X1_09	K21	70	Y2_01 to X2_09	K69
23	Y1_01 to X1_10	K22	71	Y2_01 to X2_10	K70
24	Y1_01 to X1_11	K23	72	Y2_01 to X2_11	K71
25	Y1_02 to X1_00	K24	73	Y2_02 to X2_00	K72
26	Y1_02 to X1_01	K25	74	Y2_02 to X2_01	K73
27	Y1_02 to X1_02	K26	75	Y2_02 to X2_02	K74
28	Y1_02 to X1_03	K27	76	Y2_02 to X2_03	K75
29	Y1_02 to X1_04	K28	77	Y2_02 to X2_04	K76
30	Y1_02 to X1_05	K29	78	Y2_02 to X2_05	K77
31	Y1_02 to X1_06	K30	79	Y2_02 to X2_06	K78
32	Y1_02 to X1_07	K31	80	Y2_02 to X2_07	K79
33	Y1_02 to X1_08	K32	81	Y2_02 to X2_08	K80
34	Y1_02 to X1_09	K33	82	Y2_02 to X2_09	K81
35	Y1_02 to X1_10	K34	83	Y2_02 to X2_10	K82
36	Y1_02 to X1_11	K35	84	Y2_02 to X2_11	K83
37	Y1_03 to X1_00	K36	85	Y2_03 to X2_00	K84
38	Y1_03 to X1_01	K37	86	Y2_03 to X2_01	K85
39	Y1_03 to X1_02	K38	87	Y2_03 to X2_02	K86
40	Y1_03 to X1_03	K39	88	Y2_03 to X2_03	K87
41	Y1_03 to X1_04	K40	89	Y2_03 to X2_04	K88
42	Y1_03 to X1_05	K41	90	Y2_03 to X2_05	K89
43	Y1_03 to X1_06	K42	91	Y2_03 to X2_06	K90
44	Y1_03 to X1_07	K43	92	Y2_03 to X2_07	K91
45	Y1_03 to X1_08	K44	93	Y2_03 to X2_08	K92
46	Y1_03 to X1_09	K45	94	Y2_03 to X2_09	K93
47	Y1_03 to X1_10	K46	95	Y2_03 to X2_10	K94
48	Y1_03 to X1_11	K47	96	Y2_03 to X2_11	K95

MT-X745 Specifications

Specifications are valid at 23 °C unless otherwise noted.

Input Characteristics

Topology	1-wire, 4 × 12, matrix, 2 banks
Maximum switching voltage	220V DC, 250V AC
Maximum switching power (per channel)	
AC	62.5 VA
DC (30 V to 220 V)	60 W
Maximum current (per channel)	2 A
DC path resistance	
Initial	<0.8 Ω
End-of-life	≥1.8 Ω
Relay operate time	
Typical	3 ms
Maximum	6 ms

Safety Voltages

This product is designed to meet the requirements of the following electrical equipment safety standards for measurement, control, and laboratory use:

- IEC 61010-1, EN 61010-1
- UL 61010-1, CSA C22.2 No. 61010-1

CE Compliance

This product meets the essential requirements of applicable European Directives, as follows:

- 2014/35/EU; Low-Voltage Directive (safety)
- 2014/30/EU; Electromagnetic Compatibility Directive (EMC)
- 2014/34/EU; Potentially Explosive Atmospheres (ATEX)

Shock and Vibration

To meet these specifications, you must panel mount the system.

Random vibration

Operating (IEC 60068-2-64)	0.3g _{rms} , 5 Hz to 500 Hz
Nonoperating (IEC 60068-2-6)	2.4g _{rms} , 5 Hz to 500 Hz
Operating shock (IEC 60068-2-27)	30 g, 11 ms half sine;

Environmental

Refer to the manual for the chassis you are using for more information about meeting these specifications.

Operating temperature	0 °C to 55 °C
Storage temperature	-20°C to 70 °C
Operating humidity (IEC 60068-2-78)	10% RH to 90% RH, noncondensing
Storage humidity (IEC 60068-2-78)	5% RH to 95% RH, noncondensing Pollution
Degree	2
Maximum altitude	2,000 m

Config文本

MT-DAQ设备的开发和使用依赖于Config配置文本，只有正确配置该文本，才能保证设备的正常运行。不同型号的设备或板卡对应的配置参数是不同的。Python、LabVIEW和C#三种编程语言的Config配置文本完全相同。

通用Config配置文本通过MT-Master软件主页导出获得，用户可以根据实际设备或板卡的参数对配置文本进行修改配置，或者按照文本默认参数配置运行。

Config配置文本中的各项参数含义及其具体配置可以参考MT-DAQ上手指南，指南链接附于下文Support板块。

使用MT产品过程中如有任何疑问，可以通过访问官网：<http://www.mangotree.cn>联系专业客服咨询。



MangoTree官网

Support

MT-Master上手指南:

<http://server.mangotree.cn:9900/WebFile/Downloads/上手指南/MT-Master/>



Master上手指南

MT-Master视频教程:

<http://server.mangotree.cn:9900/WebFile/Downloads/视频教程/MT-Master/>



Master视频教程

MT-DAQ上手指南:

<http://server.mangotree.cn:9900/WebFile/Downloads/上手指南/MT-DAQ/>



DAQ上手指南

MT-DAQ视频教程:

<http://server.mangotree.cn:9900/WebFile/Downloads/视频教程/MT-DAQ/>



DAQ视频教程

